



AMERICA'S BEST VALUE IN SWING SETS.™

Orangutan Fort Installation Manual

Version 10.15



Tools Needed for Assembly

Tape Measure	24" Level	Angle Square
Phillips Screw Driver	3/8" Cordless Drill or Electric Drill	3/8" Drive Ratchet or Electric Impact Gun
Claw Hammer or Rubber Mallet	Pliers or Vise Grips	7/16" Deep Well Socket
9/16" Deep Well Socket	3/4" Deep Well Socket	1/8", 1/4", and 9/16" Drill Bits
Phillips Head Screw Bits	An Adult with two Adult Helpers	

Please familiarize yourself with the install manual, parts/components and general construction process of your new swing set before getting started. Approximate assembly time: 6 to 8 hours. 6 foot unobstructed safety perimeter around swing set recommended.

Choosing A Location For Your Playset

When choosing a location for your swing set, always keep your child or children's safety in mind. Here are some recommendations to help you locate and install a safe play area.

- This play set is designed for the use of 4 occupants who have a combined weight not exceeding 800 pounds on the elevated floor; 3 occupants who have a combined weight of 525 pounds on the swing area; for a total Unit capacity of 5 occupants who have a combined weight of 1325. (this weight is not including the picnic table area)
- On-site adult supervision is required.
- The swing set should be located on level ground. The stationary components such as ladders and slides are required to be a minimum of six feet from any structure or obstruction such as a fence, garage, house, tree, overhanging branches, electrical wires, clotheslines, etc. Any swinging equipment is also required to be a minimum distance twice the height of the swing beam away from these obstructions or structures as well. The swing set should be located a safe distance from any water hazards, such as a lake, river, bayou, swimming pool, etc.
- Do not install this residential swing set in a commercial setting. This swing set is not manufactured for commercial usage and will void all warranties. Tree Frogs Wooden Swing Set Factory is not responsible for any damages or injuries resulting from this swing set being used in a commercial setting.
- Never install this swing set indoors; or over concrete, asphalt, packed earth, grass, carpet or any other hard surface. A fall onto a hard surface can result in serious or fatal injury.
- The U.S. Consumer Product Safety Commission (CPSC) recommends that you install and maintain a resilient surface under your swing set. The CPSC's Consumer Information Sheet for Playground Surfacing Materials is on the next page. A resilient surface, should be installed after the swing set has been completely assembled according to these instructions. The swing set must rest on solid ground. Please note that this swing set has a maximum fall height of 7'.

Maintaining Your Swing Set

Here are some maintenance tips required to insure safe play on your swing set for years of fun.

- At the beginning of each usage season and every two weeks during, check: nuts and bolts and tighten as needed, swing seats, chains, ladders, slides, rope and wood components for sign of deterioration and replace if necessary.
- On a yearly basis, we recommend that you coat your swing set with a sealant or preservative. You may also want to spot sand any areas prior to sealing.

** Special note: Although we recommend that you reseal your swing set annually, you may have to touch up the high traffic areas and/or areas that have a high exposure to direct sunlight.**

- Be sure that the sealant you select is non-toxic and child safe. Your local Tree Frogs Wooden Swing Set Factory dealer may offer a complete power wash and reseal and maintenance program.
- Do not use line trimmers or "weed eaters" around your swing set. The line will remove both paint and wood from uprights and base pieces. Any damage resulting from this type of abuse is not covered under our limited warranty.
- Remove plastic swing seats and take in doors or do not use when temperature drops below 0°F.

Weight Limits for Tree Frogs Swing Sets

Fort Platform: 800 Lbs. Total Weight

Swing Belts: 175 Lbs.

Trapeze: 125 Lbs.

Full Bucket Swing: 50 Lbs.

Toddler Bucket Swing: 50 Lbs.

Tire Swing: 125 Lbs. Total Weight

Rope Ladder: 75 Lbs.

Rock Wall: 150 Lbs.

All Slides: 125 Lbs.

Tree Frogs recommends that the weight limits for all components must not be exceeded. Failure to adhere to these and other safety guidelines could result in damage to the swing set and/or injury to the users.

Please keep this install manual for future reference.

To insure SAFE PLAY adults must teach children:

- Not to walk close to, in front of, behind, or between moving items.
- Not to swing empty swing seats.
- Not to swing sideways into the path of adjacent swings.
- Not to use the swing set in a manner other than that for which it is intended.
- Not to get off the equipment while it is in motion.
- Not to jump off the tower.
- Not to stand in the swing seats.
- Not to swing so high that chains become slack, or above the height of the swing support.
- Not to jump on a slide.
- Not to climb on top of the swing support.
- Not to attach to the swing set any item that is not specifically designed for use with the equipment, such as (but not limited to) jump ropes, clotheslines, pet leashes, cables, and chains. These may become strangulation hazards.
- To hold on to swings and climbers with both hands.
- To slide feet first, never head first.
- To watch for other children while swinging or playing near the swing set.

To also insure SAFE PLAY adults must:

- Limit climbing and swinging heights to each child's ability.
- Verify that suspended climbing ropes are secured at both ends.
- Verify that suspended climbing ropes cannot be looped back on themselves.
- Dress children appropriately for play. Use well-fitted shoes that do not have slippery soles.
- Avoid ponchos, scarves, hoods, loose fitting clothing, neckties, and any clothing with a drawstring. Serious injury could result should any part of the children's clothing become entangled in the swing set.
- Do not allow children to play wearing helmets.
- Remember that children are inventive. When they develop games that are unsafe, be alert and change the rules.

IMPORTANT - PLEASE READ

As fresh lumber acclimates to its new environment, the natural tendencies of the tree can show itself in the form of checks, or "cracks" in the lumber. In almost all cases this is normal and it will not affect the structural integrity of your play set.

Cosmetic defects that do not affect the structural integrity of the product, or natural defects of wood such as warping, checking or any other physical properties of wood that do not present a safety hazard, are not covered by this warranty.

Defects that develop because the product is exposed to extreme climate conditions are not covered by this warranty.

Defects that develop as a result of faulty or improper installation of the product are also not covered by this warranty.

Most cracks are not warrantable, however if you believe that the integrity of your play set is compromised by this natural occurrence, please contact the Tree Frogs Swing Set Dealer that you purchased your swing set from.

We appreciate your purchase and know that you will enjoy your play system for many years to come.

Pre-Assembly Hints

- Depending on your experience, assembly of our play sets can take as little as 6 hours up to 24 hours, depending on size, after inventory of parts; therefore, we recommend you set aside a full two days for assembly.
- Identify all of the parts for your play set. Empty each box and lay out boards so you can see each part. Your instruction book will have detailed drawings that will make it easy for you to recognize individual parts. Keep all hardware and metal parts separate from wooden pieces.
- After everything is laid out, check carefully to ensure all parts are present. Make sure there are no broken boards.
- Find an area to sort your hardware. It is best to open the hardware on a solid surface so that you do not lose any pieces in the grass. This will save time and familiarize you with all the different pieces in the hardware bag.

****Important note:** Wood has some natural defects such as knots, surface cracks, etc... We reject parts that are structurally defective. We use a high quality lumber in our structures; however, you should inspect each part for splinters or rough spots and sand them smooth to prevent injury.**

- After familiarizing yourself with all of the components, read all instructions thoroughly. Reading instructions after you have studied the parts will help you understand more clearly the installation process, and help to eliminate unnecessary mistakes.
- Pay close attention to the diameter and length of each bolt and screw.
- Never tighten hardware completely at first. It helps to have some adjustment for bolt alignment while you are attaching parts together. After everything is square, tighten each joint.
- After the main unit is assembled it is critical that the floor is level and square. If the main frame is not level, the walls and floor will be out of square.
- After you complete installation, make sure every bolt, screw, and nut is tight, and every board is secure. Wood will expand and contract with the seasons.
- Place the set on level ground, not less than 6ft from any structure or obstruction such as a fence, garage, house, overhanging branches, laundry lines, or electrical wires.
- All 1/4" and 3/8" lag bolts must have pre-drilled holes 1-1/2" to 2" deep. Use a 1/8" drill bit for the 1/4" lag bolts and 1/4" drill bit for 3/8" lag bolts. Use pre-drilled holes in facias as a reference for placing lag bolt pilot holes.
- If a board lifts or rises causing a gap between boards when running in lag bolts or screws, back out the screw or lag bolt and press or apply pressure (but not enough to crack or break board) while re-running in the lag bolt or screw in the same hole.
- Do not over tighten bolts, lag bolts or screws. You can damage boards, break hardware, and/or strip out the hardware.
- When using hammer do not beat on the hardware, but gently tap it in. Never beat on the wood as it will leave marks.

Leveling Your Swing Set During Assembly

- Complete the steps which will be the basic frame of the fort {i.e. four corner posts with base (sand box boards) and deck supports}
- Position in the most level area chosen for the play set, keeping in mind the location and size of the swing beam, ladder, slides, etc. that extend off the fort.
- Once the frame is in the final position, check for vertical and horizontal levelness to determine which side(s) will need to be dug into the ground to level the play set.
- With a shovel, score the ground around the outside edges of the sandbox boards on the 'high' side of the fort. This is the area that will be dug in. Make sure to score deep enough; the scored lines will be your digging template.
- Push the frame off and away from the scored area, far enough to dig and remove dirt to reach the appropriate depth.
- Dig a channel along the scored line(s) for the base of the fort (corner post and sandbox boards) to rest into. Dig the channel(s) to the same level depth. The bottom of the channel(s) should be level to each other so your frame doesn't teeter or rock because the channel(s) are uneven.
- Once you have removed enough grass and dirt, slide/push the frame into the channel(s). Place a level on the vertical and horizontal boards of the frame to determine if enough soil, or too much, was removed.
- Repeat this process until the basic frame is plumb and level and in its final position before completing the rest of the assembly.
- Measure to make sure fort is square.

**** Important:** if you require a channel depth of more than 6", then we recommend you have your play set area professionally graded before completing assembly. **

CONSUMER INFORMATION SHEET FOR PLAYGROUND SURFACING MATERIALS

The U.S. Consumer Product Safety Commission (CPSC) estimates that about 100,000 playground equipment related injuries resulting from falls to the ground surface are treated annually in U.S. hospital emergency rooms. Injuries involving this hazard pattern tend to be among the most serious of all playground injuries, and have the potential to be fatal, particularly when the injury is to the head. The surface under and around playground equipment can be a major factor in determining the injury-causing potential of a fall. It is self-evident that a fall onto a shock-absorbing surface is less likely to cause a serious injury than a fall onto a hard surface. However, it should be recognized that some injuries from falls will occur no matter what playground surfacing material is used.

Playground equipment should never be placed on hard surfaces such as concrete or asphalt. Grass may appear to be acceptable, but can turn to hard packed earth in areas of high traffic. Shredded bark mulch, wood chips, or fine gravel are considered to be acceptable shock absorbing surfaces when installed and maintained at a sufficient depth under and around play equipment.

TABLE 1 -CRITICAL HEIGHTS (in feet) OF TESTED MATERIAL

MATERIAL	UNCOMPRESSED DEPTH			COMPRESSED DEPTH
	6 Inch	9 Inch	12 Inch	9 inch
Wood Chips	7	10	11	10
Double Shredded Bark Mulch	6	10	11	7
Engineered Wood Fibers	6	7	>12	6
Fine Sand	5	5	9	5
Coarse Sand	5	5	6	4
Fine Gravel	6	7	10	6
Medium Gravel	5	5	6	5
Shredded Tires**	10-12	N/A	N/A	N/A

** This is data from tests conducted by independent testing laboratories on a 6 inch depth of uncompressed shredded tire samples produced by four manufacturers. The test reported critical heights, which varied from 10 feet to greater than 12 feet. It is recommended that persons seeking to install shredded tires as a protective surface request test data from the supplier showing the critical height of the material when it was tested in accordance with ASTM F1292.

Table 1 should be read as follows: If, for example, uncompressed wood chips are used at a minimum of 6 inches, the Critical Height is 7 feet. If 9 inches of uncompressed wood chips are used, the Critical Height is 10 feet. It should be noted that, for some materials, the Critical Height decreases when the material is compressed. It is recommended that a shock absorbing material should extend a minimum of 6 feet in all directions from the perimeter of stationary equipment such as climbers and slides. However, because children may deliberately jump from a moving swing, the shock absorbing material should extend in the front and rear of a swing a minimum distance of 2 times the height of the pivot point measured from a point directly beneath the pivot on the supporting structure.

This information is intended to assist in comparing the relative shock-absorbing properties of various materials. No particular material is recommended over another. However, each material is only effective when properly maintained. Materials should be checked periodically and replenished to maintain correct depth as determined necessary for your equipment. The choice of a material depends on the type and height of the playground equipment, the availability in your area, and its cost.

This information has been extracted from the CPSC publications “Playground Surfacing-Technical Information Guide” and “Handbook for Public Playground Safety.” Copies of these reports can be obtained by sending a postcard to:

Office of Public Affairs
U.S. Consumer Product Safety Commission
Washington, D.C. 20207
Toll-free Hotline: 1-800-638-2772 or at <http://www.cpsc.gov>

Orangutan Fort - Lumber

Item No.	Board Length	Part Description	QTY.
OFB-1	27 5/16"	RAIL PICKET	15
OFB-2	42"	END DECK BOARD	2
OFB-3	44"	END TARP BOARD	2
OFB-4	48"	CENTER POST FACIA	2
OFB-5	48"	SLIM DECK BOARD	2
OFB-6	44"	BLANK ROCKWALL BOARD- RIPPED	1
OFB-7	43 1/2"	DECK SUPPORT	1
OFB-8	44"	CENTER TARP BOARD	1
OFB-9	44"	SWINGBEAM SIDE FACIA	1
OFB-10	48"	DECK SIDE FACIA	1
OFB-11	48"	LADDER SIDE FACIA	1
OFB-12	55 1/4"	ROCKWALL CENTER SUPPORT	1
OFB-13	68"	CENTER POST	2
OFB-14	44"	4-HOLE FACIA	1
OFB-15	44"	BLANK ROCKWALL BOARD	4
OFB-16	44"	ROCKWALL BOARD W/ HOLES	5
OFB-17	44"	ROCKWALL BOARD W/ ROPE HOLE	1
OFB-18	48"	LARGE DECK BOARD	6
OFB-19	80 3/4"	BOTTOM ROCKWALL RUNNER (L)	1
OFB-20	80 3/4"	BOTTOM ROCKWALL RUNNER (R)	1
OFB-21	91 1/4"	SWINGBEAM SIDE RUNNER	1
OFB-22	17"	LADDER STEP	4
OFB-23	47 3/8"	SIDE SUPPORT	2
OFB-24	55 7/8"	ROCKWALL SUPPORT	2
OFB-25	56"	LEFT STEP LADDER LEG	1
OFB-26	56"	RIGHT STEP LADDER LEG	1
OFB-27	44"	MAINBEAM	2
OFB-28	7 13/16"	SMALL A- FRAME BLOCK	1
OFB-29	11"	ROPE BLOCK	1
OFB-30	13"	A-FRAME BLOCK SUNK	1
OFB-31	13"	A-FRAME BLOCK	1
OFB-32	19"	TRAPEZE ARM GUSSET	1
OFB-33	44"	SWINGBEAM TOP JOIST	1
OFB-34	60"	A-FRAME CROSSMEMBER	1
OFB-35	79 1/2"	TRAPEZE ARM	1
OFB-36	92"	A-FRAME LADDER LEG	2
OFB-37	93 1/8"	2- HOLE CORNER POST	4
OFB-38	91 3/4"	2 POS. SWINGBEAM	1

Orangutan Fort - Base Hardware

Item No.	Part No.	Part Description	QTY.
OFH-1	40-1-00001	3/8" ACORN NUT PLATED	14
OFH-2	40-1-00055	1/4" X 3" HEX LAG SCREW	44
OFH-3	40-1-00069	#14 X 1 1/4" PAN PHILLIPS T/S	2
OFH-4	40-1-00122	#14 X 1" PAN PHILLIPS T/S	8
OFH-5	40-1-00123	1 1/2" COATED DECK SCREW	40
OFH-6	40-1-00104	2" COATED DECK SCREW	52
OFH-7	40-1-00064	3/8" NYLON INSERT LOCKNUT	4
OFH-8	40-1-00026	3/8" HEX NUT	6
OFH-9	40-1-00005	3/8" X 2 1/2" CARRIAGE BOLT	2
OFH-10	40-1-00059	3/8" X 3 1/2" HEX LAG SCREW	8
OFH-11	40-1-00061	3/8" X 5" HEX LAG SCREW	2
OFH-12	40-1-00119	3/8" X 4 1/4" HEX BOLT	4
OFH-13	40-1-00042	3/8" X 4 1/2" HEX BOLT	4
OFH-14	40-1-00117	3/8" X 6" HEX BOLT	4
OFH-15	40-1-00127	3/8" X 2" HEX BOLT	4
OFH-16	40-1-00040	3/8" X 1" HEX BOLT	2
OFH-17	40-1-00073	3/8" SPLIT LOCKWASHER	10
OFH-18	40-1-00081	1/4" USS FLATWASHER	54
OFH-19	40-1-00082	3/8" USS FLATWASHER	27
OFH-20	40-1-00083	1/2" USS FLATWASHER	2
OFH-21	40-1-00080	3/8" 4-PRONG T-NUT	10
OFH-22	41-1-00025	3/8" BOLT CUP	8

Orangutan Fort - Rockwall Hardware

RWH-1	40-1-00123	1 1/2" COATED DECK SCREW	11
RWH-2	40-1-00104	2" COATED DECK SCREW	44
RWH-3	40-1-00066	1/4" X 1 1/4" PAN PHILLIPS M/S	20
RWH-4	40-1-00077	1/4" 4 PRONG T- NUT	20
RWH-5	40-1-00081	1/4" USS FLATWASHER	20

Orangutan Fort - Step Ladder Hardware

SLH-1	40-1-00041	3/8" X 1 1/2" HEX BOLT	2
SLH-2	40-1-00080	3/8" 4- PRONG T- NUT	2
SLH-3	40-1-00073	3/8" SPLIT LOCKWASHER	2
SLH-4	40-1-00022	2 1/2" COATED DECK SCREW	16

Orangutan Fort - Swingbeam Hardware

Item No.	Part No.	Part Description	QTY.
SBH-1	40-1-00001	3/8" ACORN NUT PLATED	10
SBH-2	40-1-00002	1/2" ACORN NUT PLATED	8
SBH-3	40-1-00129	1/2" X 3" CARRIAGE BOLT	2
SBH-4	40-1-00090	1/2" X 6 1/2" CARRIAGE BOLT	4
SBH-5	40-1-00101	1/2" X 8 1/2" CARRIAGE BOLT	1
SBH-6	40-1-00026	3/8" HEX NUT	2
SBH-7	40-1-00028	1/2" HEX NUT	8
SBH-8	40-1-00044	3/8" X 6 1/2" HEX BOLT	8
SBH-9	40-1-00061	3/8" X 5" HEX LAG SCREW	2
SBH-10	40-1-00064	3/8" NYLON INSERT LOCKNUT	8
SBH-11	40-1-00073	3/8" SPLIT LOCKWASHER	10
SBH-12	40-1-00074	1/2" SPLIT LOCKWASHER	8
SBH-13	40-1-00082	3/8" USS FLATWASHER	12
SBH-14	40-1-00083	1/2" USS FLATWASHER	9
SBH-15	40-1-00084	3/4" USS FLATWASHER	7
SBH-16	40-1-00088	3/8" X 9" HEX BOLT	2
SBH-17	40-1-00122	#14 X 1" PAN PHILLIPS T/S	2
SBH-18	40-1-00131	1/2" X 10 1/2" HEX BOLT	1
SBH-19	41-1-00025	3/8" BOLT CUP	10

Orangutan Fort - Accessories

OFA-1	56-1-00012	DUCTILE IRON SWING HANGER	6
OFA-2	57-2-00004	1 1/4" PLAYGRIP SAFETY HANDLE	2
OFA-3	58-1-00014	SWINGBEAM 45 DEGREE BRACKET	1
OFA-4	59-1-00011	SPRING CLIPS 10MM X 100MM	6
OFA-5	60-1-00005	16" TRAPEZE BAR W/ RINGS	1
OFA-6	58-1-00010	SWINGBEAM TRI- PLATE	1
OFA-7	58-1-00004	SMALL 90 DEGREE BRACKET	2
OFA-8	58-1-00012	90 DEGREE LADDER BRACKET	2
OFA-9	65-7-00015	12' ROPE	1
OFA-10	36-1-00024	ROCKWALL ROCKS	10
OFA-11	60-1-00004	56" CHAINED BELT SWING	2
OFA-12	37-1-00021	TELESCOPE	1
OFA-13	37-1-00017	12" SHIP'S WHEEL	1
OFA-14	70-2-00066	37" X 73" FORT TARP	1

Orangutan Fort - Lumber

OFB-1
27 5/16" Rail Picket
QTY. 15



OFB-2
42" End Deck Board
QTY. 2



OFB-3
44" End Tarp Board
QTY. 2



OFB-4
48" Center Post Facia
QTY. 2



OFB-5
48" Slim Deck Board
QTY. 2



OFB-6
44" Blank Rockwall Board- Ripped
QTY. 1



OFB-7
43 1/2" Deck Support
QTY. 1



OFB-8
44" Center Tarp Board
QTY. 1



OFB-9
44" Swingbeam Side Facia
QTY. 1



OFB-10
48" Deck Side Facia
QTY. 1



OFB-11
48" Ladder Side Facia
QTY. 1



OFB-12
55 1/4" Rockwall Center Support
QTY. 1



Orangutan Fort - Lumber

OFB-13
68" Center Post
QTY. 2



OFB-14
44" 4-Hole Facia
QTY. 1



OFB-15
44" Blank Rockwall Board
QTY. 4



OFB-16
44" Rockwall Board w/ Holes
QTY. 5



OFB-17
44" Rockwall Board w/ Rope Hole
QTY. 1



OFB-18
48" Large Deck Board
QTY. 6



OFB-19
80 3/4" Bottom Rockwall Runner (L)
QTY. 1



OFB-20
80 3/4" Bottom Rockwall Runner (R)
QTY. 1



OFB-21
91 1/4" Swingbeam Side Runner
QTY. 1



OFB-22
17" Ladder Step
QTY. 4



OFB-23
47 3/8" Side Support
QTY. 2



OFB-24
55 7/8" Rockwall Support
QTY. 2



Orangutan Fort - Lumber

OFB-25
56" Left Step Ladder Leg
QTY. 1



OFB-26
56" Right Step Ladder Leg
QTY. 1



OFB-27
44" Mainbeam
QTY. 2



OFB-28
7 13/16" Small A-Frame Block
QTY. 1



OFB-29
11" Rope Block
QTY. 1



OFB-30
13" A-Frame Block Sunk
QTY. 1



OFB-31
13" A-Frame Block
QTY. 1



OFB-32
19" Trapeze Arm Gusset
QTY. 1



OFB-33
44" Swingbeam Top Joist
QTY. 1



OFB-34
60" A-Frame Crossmember
QTY. 1



OFB-35
79 1/2" Trapeze Arm
QTY. 1



OFB-36
92" A-Frame Leg
QTY. 2



Orangutan Fort - Lumber

OFB-37

93 1/8" 2- Hole Corner Post
QTY. 4



OFB-38

91 3/4" 2 Pos. Swingbeam
QTY. 1



ORANGUTAN FORT- BASE HARDWARE BAG

INSTALLER NOTE: (YOU MUST ASSEMBLE THIS PRODUCT IN ACCORDANCE WITH THESE ASSEMBLY INSTRUCTIONS. WHEN COMPLETE GIVE MANUAL TO OWNER.)

OFH-1
40-1-00001
3/8" Acorn Nut Plated
QTY. 14



OFH-2
40-1-00055
1/4" x 3" Hex Lag Screw
QTY. 44



OFH-3
40-1-00069
#14 x 1 1/4" Pan Phillips T/S
QTY. 2



OFH-4
40-1-00122
#14 x 1" Pan Phillips T/S
QTY. 8



OFH-5
40-1-00123
1 1/2" Coated Deck Screw
QTY. 40



OFH-6
40-1-00104
2" Coated Deck Screw
QTY. 52



OFH-7
40-1-00064
3/8" Nylon Insert Locknut
QTY. 4



OFH-8
40-1-00026
3/8" Hex Nut
QTY. 6



OFH-9
40-1-00005
3/8" x 2 1/2" Carriage Bolt
QTY. 2



OFH-10
40-1-00059
3 1/2" Hex Lag Screw
QTY. 8



MEASUREMENT TAKEN FROM BOTTOM OF BOLT HEAD TO THE BOTTOM OF BOLT



USE THE RULER TO MEASURE YOUR BOLTS AND SCREWS. HARDWARE VIEWS SHOWN ABOVE ARE 1:1 SCALE AND CAN BE USED TO MATCH HARDWARE SIZES.

ORANGUTAN FORT- BASE HARDWARE BAG

INSTALLER NOTE: (YOU MUST ASSEMBLE THIS PRODUCT IN ACCORDANCE WITH THESE ASSEMBLY INSTRUCTIONS. WHEN COMPLETE GIVE MANUAL TO OWNER.)

OFH-11
40-1-00061
3/8" x 5" Hex Lag Screw
QTY. 2



OFH-17
40-1-00073
3/8" Split Lockwasher
QTY. 10



OFH-12
40-1-00119
3/8" x 4 1/4" Hex Bolt
QTY. 4



OFH-13
40-1-00042
3/8" x 4 1/2" Hex Bolt
QTY. 4

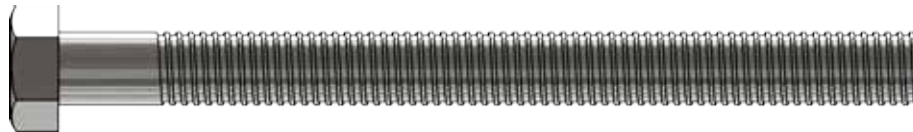

OFH-14
40-1-00117
3/8" x 6" Hex Bolt
QTY. 4



OFH-15
40-1-00127
3/8" x 2" Hex Bolt
QTY. 4



OFH-16
40-1-00040
3/8" x 1" Hex Bolt
QTY. 2



MEASUREMENT TAKEN FROM BOTTOM OF BOLT HEAD TO THE BOTTOM OF BOLT



USE THE RULER TO MEASURE YOUR BOLTS AND SCREWS. HARDWARE VIEWS SHOWN ABOVE ARE 1:1 SCALE AND CAN BE USED TO MATCH HARDWARE SIZES.

ORANGUTAN FORT- BASE HARDWARE BAG

INSTALLER NOTE: (YOU MUST ASSEMBLE THIS PRODUCT IN ACCORDANCE WITH THESE ASSEMBLY INSTRUCTIONS. WHEN COMPLETE GIVE MANUAL TO OWNER.)

OFH-18
40-1-00081
1/4" USS Flatwasher
QTY. 54



OFH-19
40-1-00082
3/8" USS Flatwasher
QTY. 27



OFH-20
40-1-00083
1/2" USS Flatwasher
QTY. 2

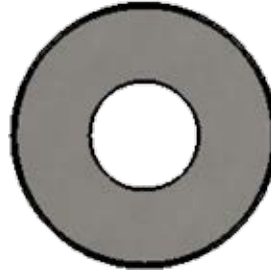

OFH-21
40-1-00080
3/8" 4-Prong T-Nut
QTY. 10

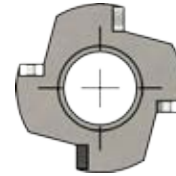

OFH-22
41-1-00025
3/8" Bolt Cup
QTY. 8



ORANGUTAN FORT- ROCKWALL HARDWARE BAG

RWH-1
40-1-00123
1 1/2" Coated Deck Screw
QTY. 11



RWH-2
40-1-00104
2" Coated Deck Screw
QTY. 44



RWH-3
40-1-00066
1/4" x 1 1/4" Pan Phillips M/S
QTY. 20



RWH-4
40-1-00077
1/4" 4-Prong T-Nut
QTY. 20



RWH-5
40-1-00081
1/4" USS Flatwasher
QTY. 20



MEASUREMENT TAKEN FROM BOTTOM OF BOLT HEAD TO THE BOTTOM OF BOLT



USE THE RULER TO MEASURE YOUR BOLTS AND SCREWS. HARDWARE VIEWS SHOWN ABOVE ARE 1:1 SCALE AND CAN BE USED TO MATCH HARDWARE SIZES.

ORANGUTAN FORT- STEP LADDER HARDWARE BAG

INSTALLER NOTE: (YOU MUST ASSEMBLE THIS PRODUCT IN ACCORDANCE WITH THESE ASSEMBLY INSTRUCTIONS. WHEN COMPLETE GIVE MANUAL TO OWNER.)

SLH-1
40-1-00041
3/8" x 1 1/2" Hex Bolt
QTY. 2

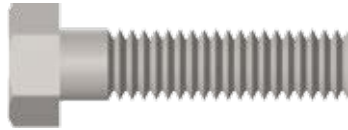

SLH-2
40-1-00080
3/8" 4-Prong T-Nut
QTY. 2

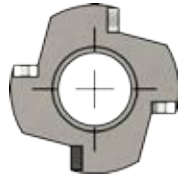

SLH-3
40-1-00073
3/8" Split Lockwasher
QTY. 2



SLH-4
40-1-00022
2 1/2" Coated Deck Screw
QTY. 16



ORANGUTAN FORT- SWINGBEAM HARDWARE BAG

SBH-1
40-1-00001
3/8" Acorn Nut Plated
QTY. 10



SBH-2
40-1-00002
1/2" Acorn Nut Plated
QTY. 8



SBH-3
40-1-00129
1/2" x 3" Carriage Bolt
QTY. 2

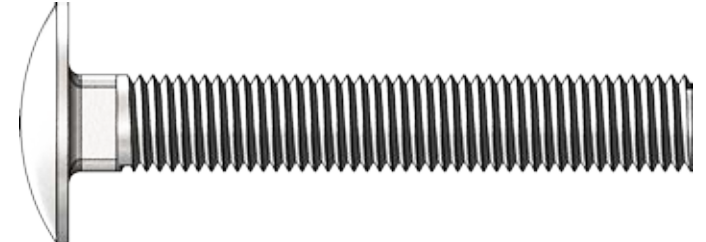

SBH-4
40-1-00090
1/2" x 6 1/2" Carriage Bolt
QTY. 4



MEASUREMENT TAKEN FROM BOTTOM OF BOLT HEAD TO THE BOTTOM OF BOLT



USE THE RULER TO MEASURE YOUR BOLTS AND SCREWS. HARDWARE VIEWS SHOWN ABOVE ARE 1:1 SCALE AND CAN BE USED TO MATCH HARDWARE SIZES.

ORANGUTAN FORT- SWINGBEAM HARDWARE BAG

INSTALLER NOTE: (YOU MUST ASSEMBLE THIS PRODUCT IN ACCORDANCE WITH THESE ASSEMBLY INSTRUCTIONS. WHEN COMPLETE GIVE MANUAL TO OWNER.)

SBH-5
40-1-00101
1/2" x 8 1/2" Carriage Bolt
QTY. 1

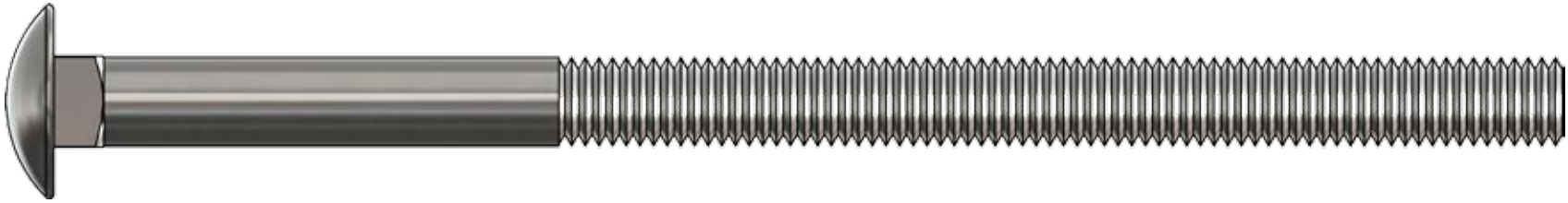

SBH-6
40-1-00026
3/8" Hex Nut
QTY. 2



SBH-7
40-1-00028
1/2" Hex Nut
QTY. 8



SBH-9
40-1-00061
3/8" x 5" Hex Lag Screw
QTY. 2



SBH-8
40-1-00044
3/8" x 6 1/2" Hex Bolt
QTY. 8



MEASUREMENT TAKEN FROM BOTTOM OF BOLT HEAD TO THE BOTTOM OF



USE THE RULER TO MEASURE YOUR BOLTS AND SCREWS. HARDWARE VIEWS SHOWN ABOVE ARE 1:1 SCALE AND CAN BE USED TO MATCH HARDWARE SIZES.

ORANGUTAN FORT- SWINGBEAM HARDWARE BAG

INSTALLER NOTE: (YOU MUST ASSEMBLE THIS PRODUCT IN ACCORDANCE WITH THESE ASSEMBLY INSTRUCTIONS. WHEN COMPLETE GIVE MANUAL TO OWNER.)

SBH-10
40-1-00064
3/8" Nylong Insert Locknut
QTY. 8



SBH-11
40-1-00073
3/8" Split Lockwasher
QTY. 10



SBH-12
40-1-00074
1/2" Split Lockwasher
QTY. 8



SBH-13
40-1-00082
3/8" USS Flatwasher
QTY. 12



SBH-14
40-1-00083
1/2" USS Flatwasher
QTY. 9

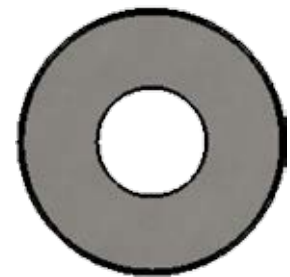

SBH-15
40-1-00084
3/4" USS Flatwasher
QTY. 7

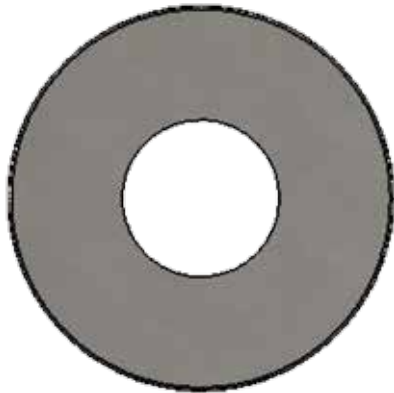

SBH-17
40-1-00122
#14 x 1" Pan Phillips T/S
QTY. 2



SBH-19
41-1-00025
3/8" Bolt Cup
QTY. 10



MEASUREMENT TAKEN FROM BOTTOM OF BOLT HEAD TO THE BOTTOM OF BOLT



USE THE RULER TO MEASURE YOUR BOLTS AND SCREWS. HARDWARE VIEWS SHOWN ABOVE ARE 1:1 SCALE AND CAN BE USED TO MATCH HARDWARE SIZES.

ORANGUTAN FORT- SWINGBEAM HARDWARE BAG

INSTALLER NOTE: (YOU MUST ASSEMBLE THIS PRODUCT IN ACCORDANCE WITH THESE ASSEMBLY INSTRUCTIONS. WHEN COMPLETE GIVE MANUAL TO OWNER.)

SBH-16
40-1-00088
3/8" x 9" Hex Bolt
QTY. 2



SBH-18
40-1-00131
1/2" x 10 1/2" Hex Bolt
QTY. 1

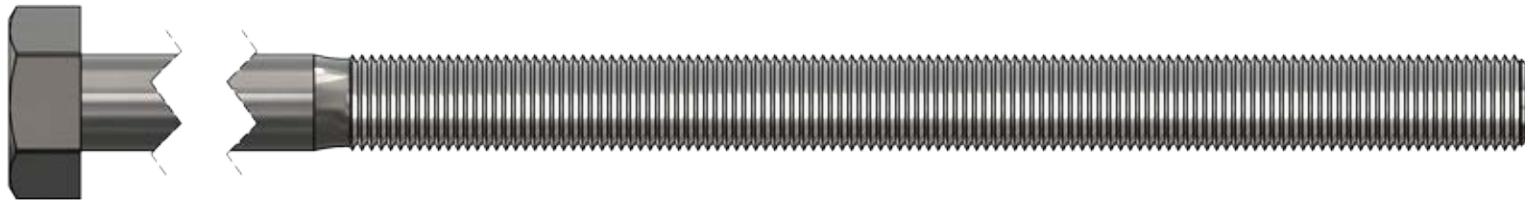

MEASUREMENT TAKEN FROM BOTTOM OF BOLT HEAD TO THE BOTTOM OF



USE THE RULER TO MEASURE YOUR BOLTS AND SCREWS. HARDWARE VIEWS SHOWN ABOVE ARE 1:1 SCALE AND CAN BE USED TO MATCH HARDWARE SIZES.

Orangutan Fort Accessories

OFA-1
56-1-00012
Ductile Iron Swing Hanger
QTY. 6



OFA-2
57-2-00004
1 1/4" Playgrip Safety Handle
QTY. 2

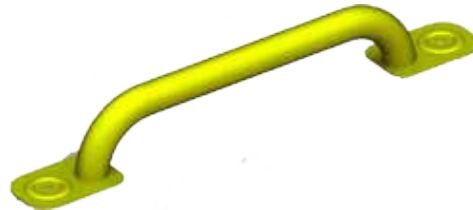

OFA-3
58-1-00014
Swingbeam 45 Degree Bracket
QTY. 1



OFA-4
59-1-00011
Spring Clips 10mm x 100mm
QTY. 6



OFA-5
60-1-00005
16" Trapeze Bar w/ Rings
QTY. 1



OFA-6
58-1-00010
Swingbeam Tri-Plate
QTY. 1

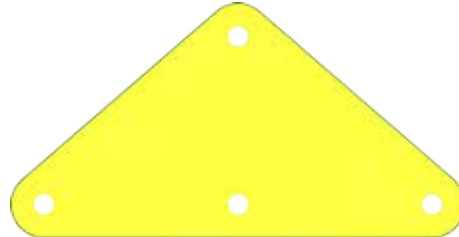

OFA-7
58-1-00004
Small 90 Degree Bracket
QTY. 2

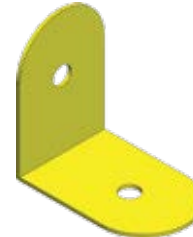

OFA-8
58-1-00012
90 Degree Ladder Bracket
QTY. 2



OFA-9
65-7-00015
12' Rope
QTY. 1



OFA-10
36-1-00024
Rockwall Rocks
QTY. 10



OFA-11
60-1-00004
56" Chained Belt Swing
QTY. 2



OFA-12
37-1-00021
Telescope
QTY. 1



Orangutan Fort Accessories

OFA-13
37-1-00017
12" Ship's Wheel
QTY. 1



OFA-14
37" x 73" Tarp
QTY. 1



Rockwall Side Wall

PARTS NEEDED

OFB-37- 93 1/8" 2- Hole Corner Post- (2)
 OFB-27-- 44" Mainbeam- (1)
 OFB-14- 44" 4- Hole Facia- (1)
 OFB-35- 79 1/2" Trapeze Arm- (1)

HARDWARE NEEDED

OFH-14- 3/8" x 6" Hex Bolt- (2)
 OFH-19- 3/8" x USS Flatwasher- (4)
 OFH-8- 3/8" Hex Nut- (2)
 OFH-12- 3/8" x 4 1/4" Hex Bolt- (2)
 OFH-18- 1/4" USS Flatwasher- (6)
 OFH-22- 3/8" Bolt Cup- (2)
 OFH-17- 3/8" Split Lockwasher- (2)
 OFH-1- 3/8" Acorn Nut Plated- (4)
 OFH-21- 3/8" 4-Prong T-Nut- (2)
 OFH-2- 1/4" x 3" Hex Lag Screw- (6)

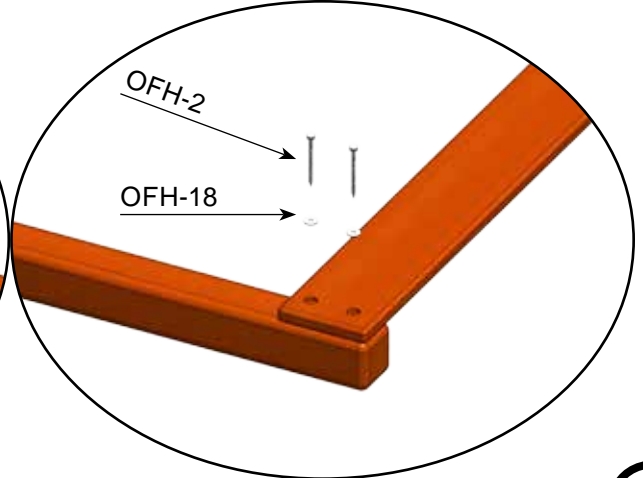
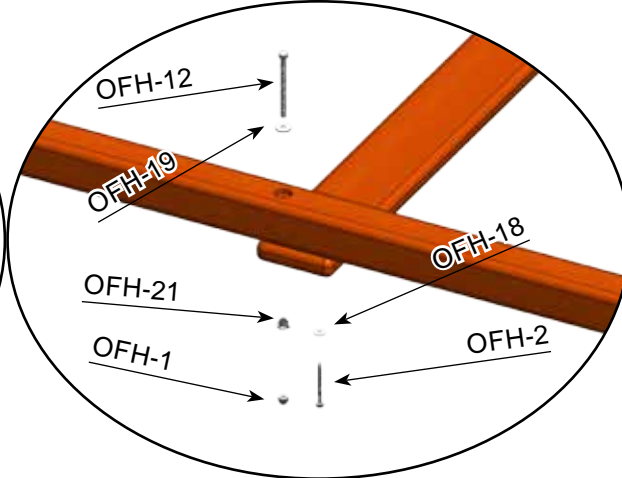
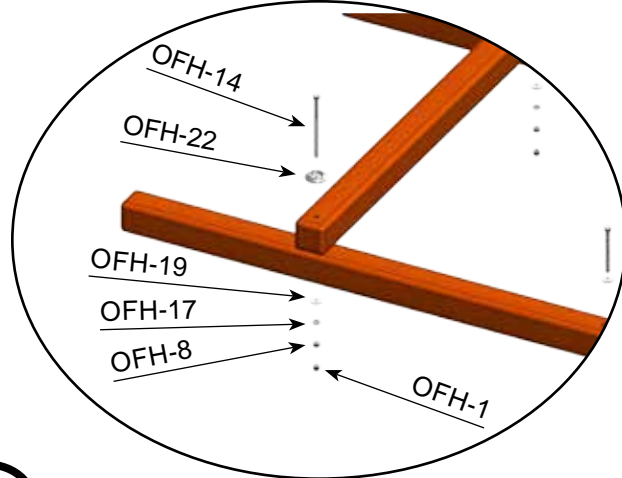
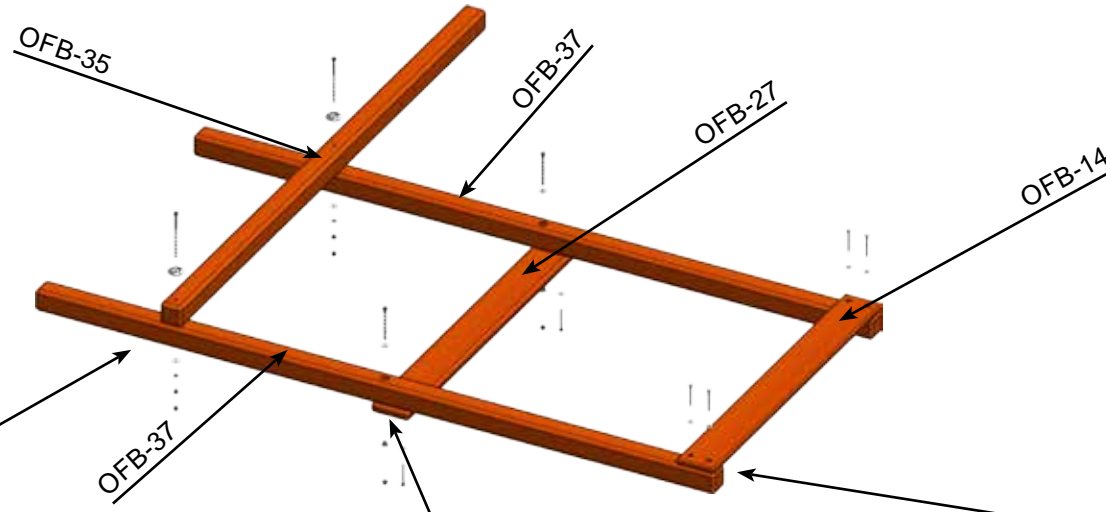
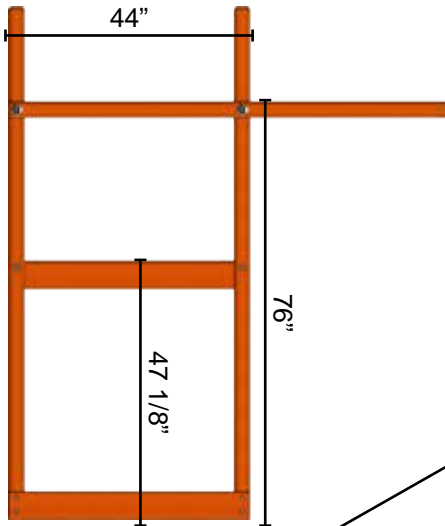

Rockwall Side Wall

PARTS NEEDED

OFB-32- 19" Trapeze Arm Gusset- (1)
 OFA-1- Ductile Iron Swing Hanger- (2)

OFH-19- 3/8" USS Flatwasher- (6)
 OFH-13- 3/8" x 4 1/2" Hex Bolt- (4)
 OFH-17- 3/8" Split Lockwasher- (4)
 OFH-1- 3/8" Acorn Nut Plated- (4)

HARDWARE NEEDED

OFH-10- 3/8" x 3 1/2" Hex Lag Screw- (2)
 OFH-22- 3/8" Bolt Cup- (4)
 OFH-7- 3/8" Nylon Insert Locknut- (4)

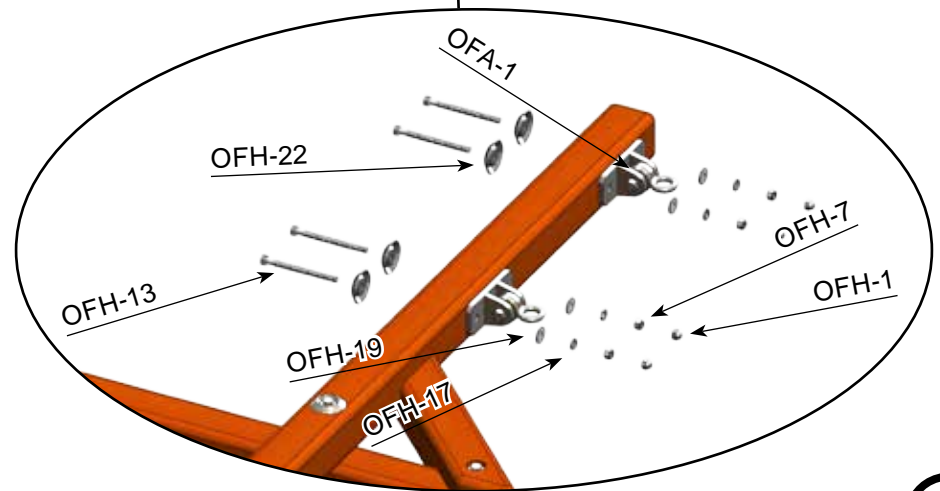
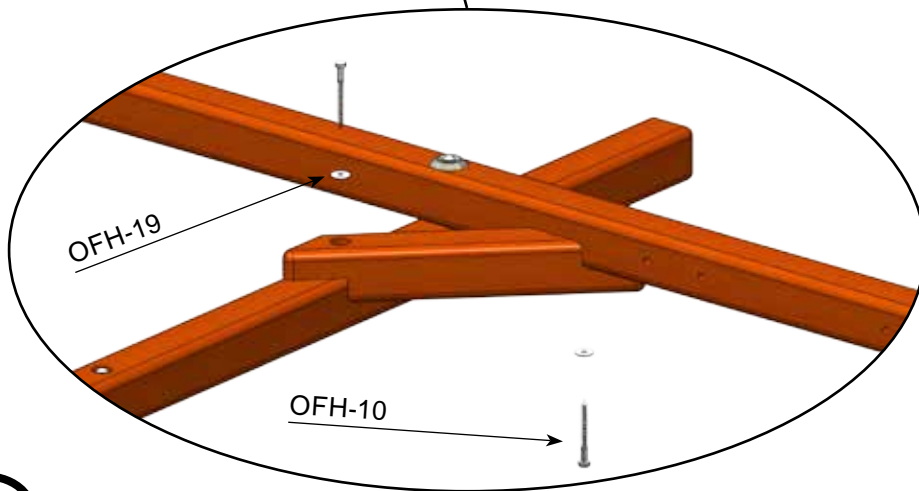
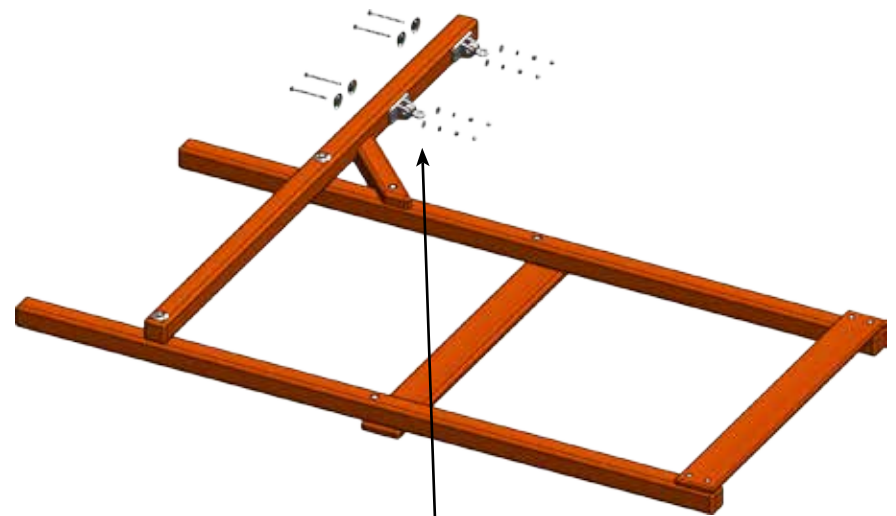
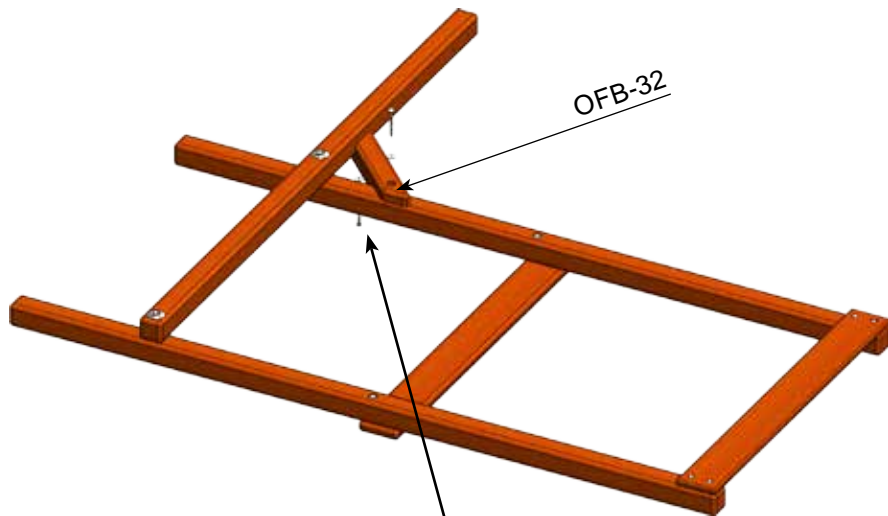

Swingbeam Side Wall

PARTS NEEDED

- OFB-33- 44" Swingbeam Top Joist- (1)
- OFB-27- 44" Mainbeam- (1)
- OFB-37- 93 1/8" 2- Hole Corner Post- (2)
- OFB-21- Swingbeam Side Runner- (1)

HARDWARE NEEDED

- | | |
|--------------------------------------|--------------------------------------|
| O FH-14- 3/8" x 6" Hex Bolt- (2) | O FH-22- 3/8" Bolt Cup- (2) |
| O FH-19- 3/8" USS Flatwasher- (4) | O FH-17- 3/8" SPlit Lockwasher- (2) |
| O FH-8- 3/8" Hex Nut- (2) | O FH-1- 3/8" Acorn Nut Plated- (4) |
| O FH-12- 3/8" x 4 1/4" Hex Bolt- (2) | O FH-21- 3/8" 4-Prong T-Nut- (2) |
| O FH-18- 1/4" USS Flatwasher- (6) | O FH-2- 1/4" x 3" Hex Lag Screw- (6) |

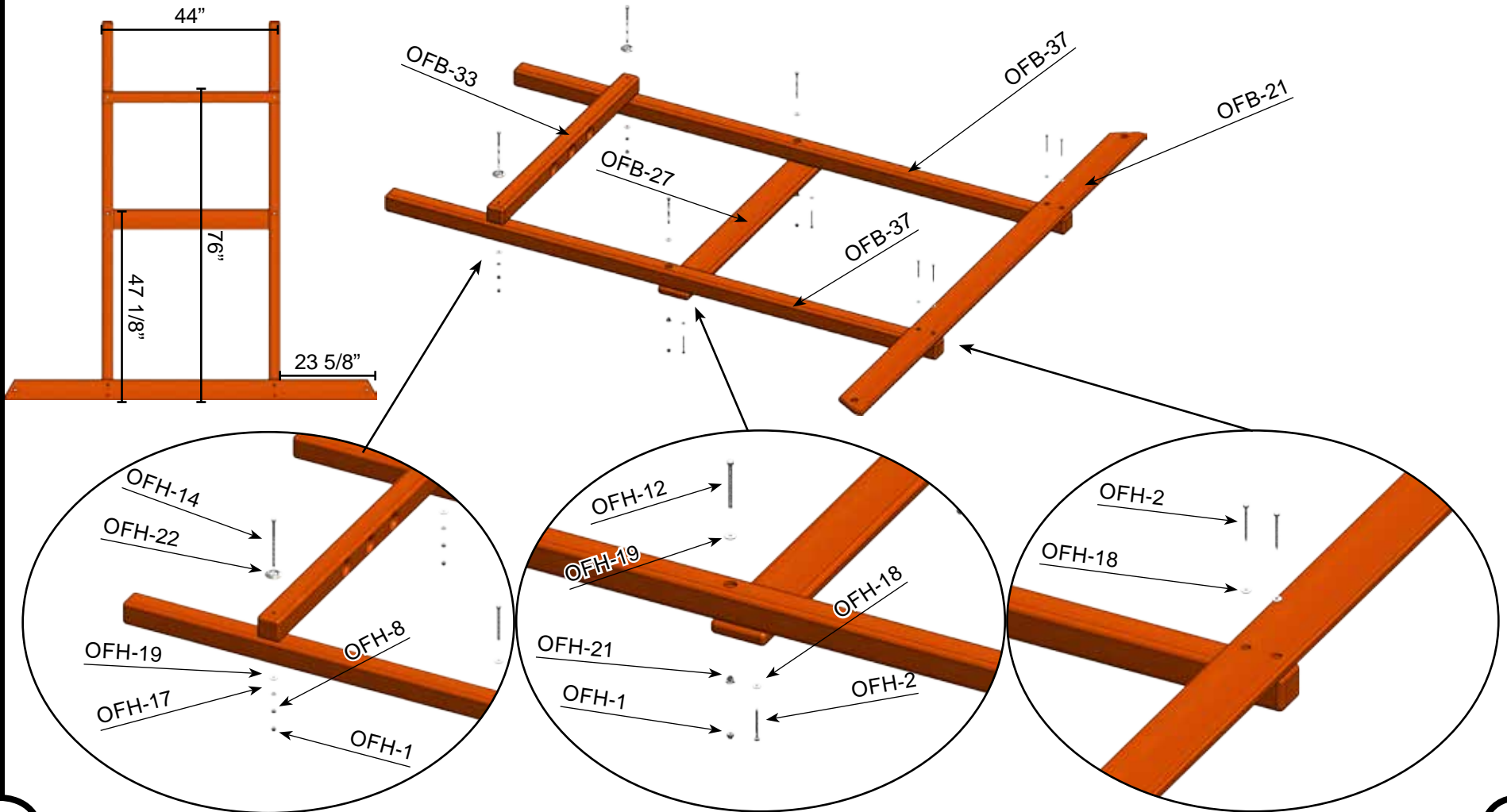

Swingbeam Side Wall

PARTS NEEDED

- OFB-9- 44" Swingbeam Side Facia- (1)
- OFB-19- 80 3/4" Bottom Rockwall Runner (L)- (1)
- OFB-20- 80 3/4" Bottom Rockwall Runner (R)- (1)

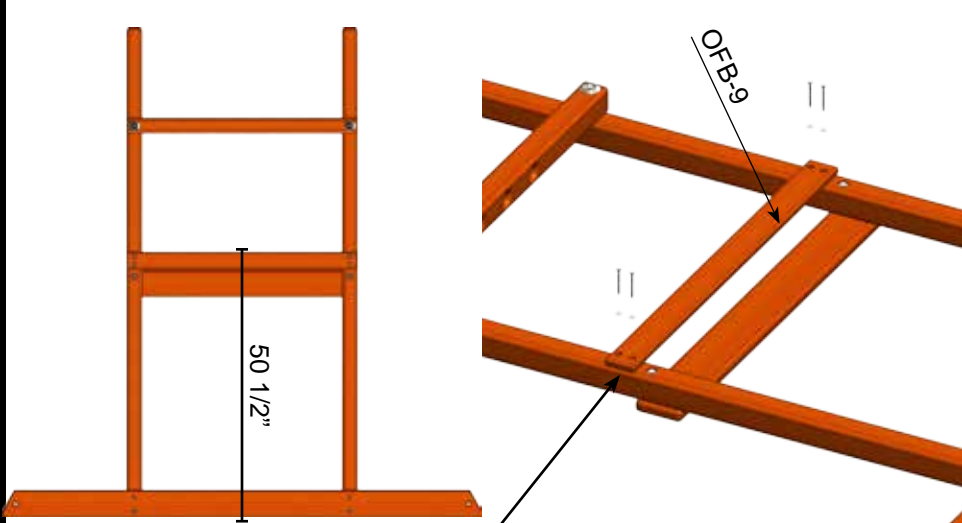

Main Assembly

HARDWARE NEEDED

- OFH-2- 1/4" x 3" Hex Lag Screw- (12)
- OFH-18- 1/4" USS Flatwasher- (12)

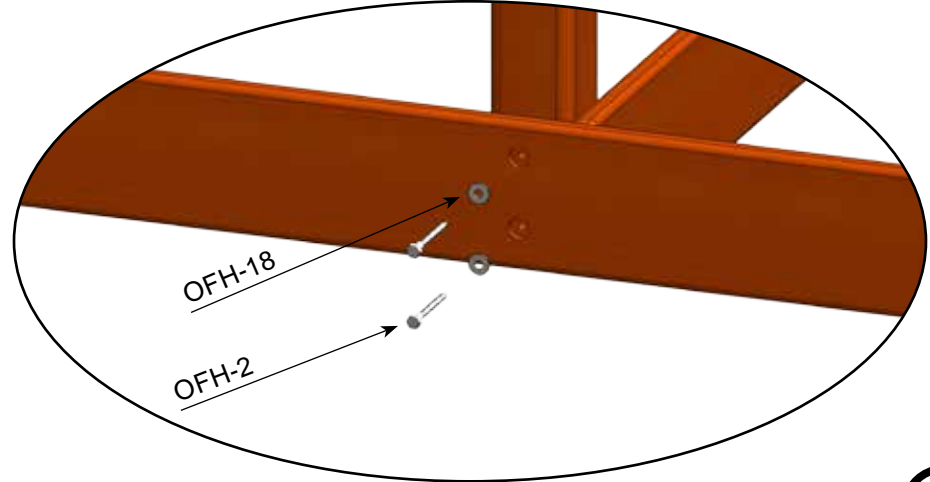
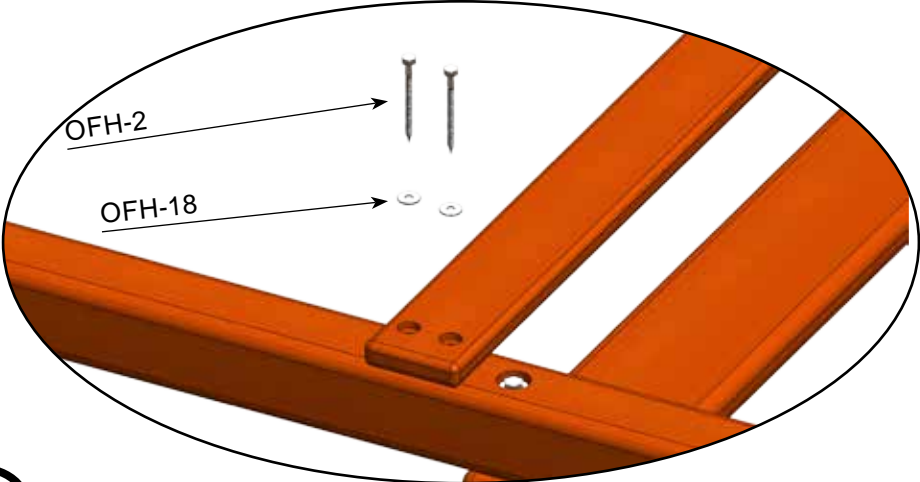
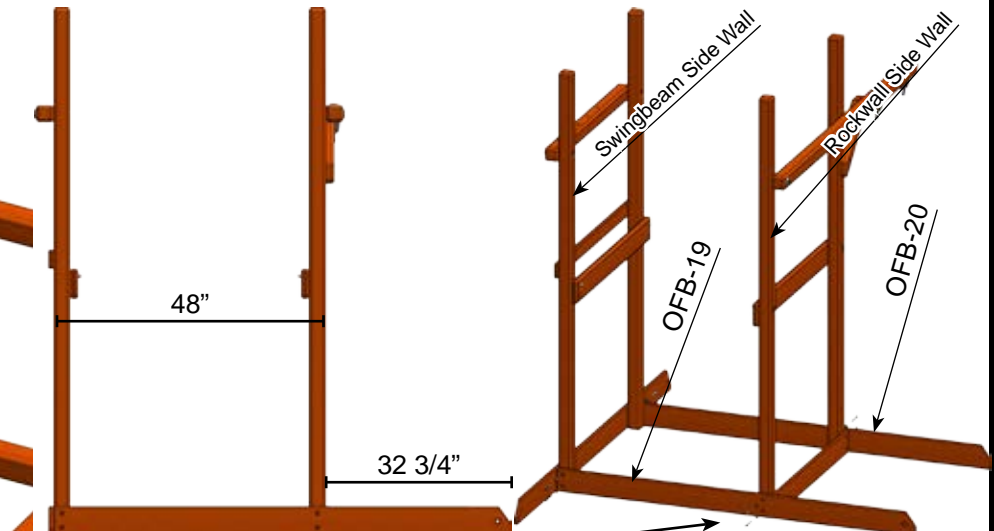

Main Assembly

PARTS NEEDED

OFB-2- 42" End Deck Board- (2)
OFB-5- 48" Slim Deck Board- (2)
OFB-18- 48" Large Deck Board- (6)

HARDWARE NEEDED

OFH-2- 2" Coated Deck Screw- (40)

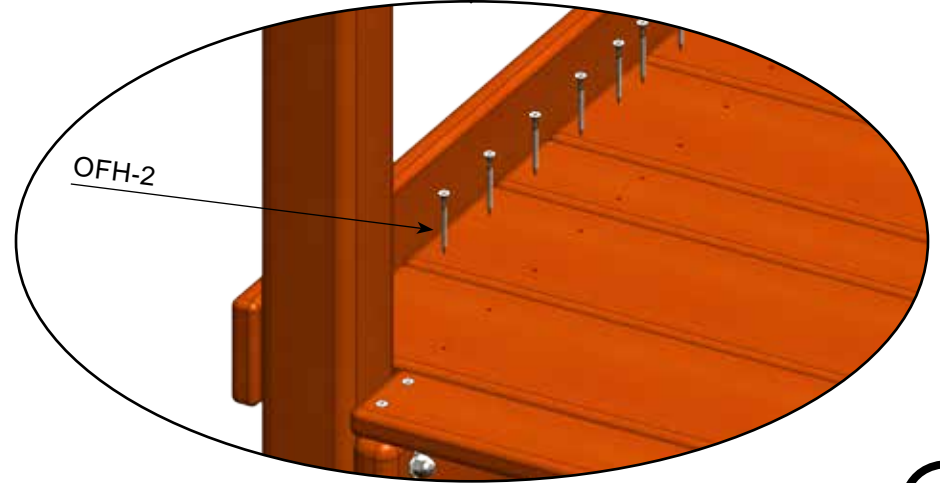
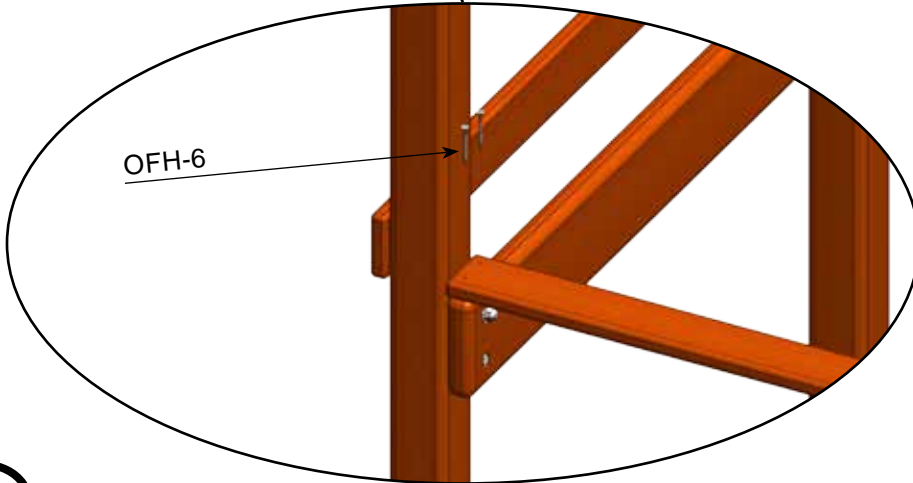
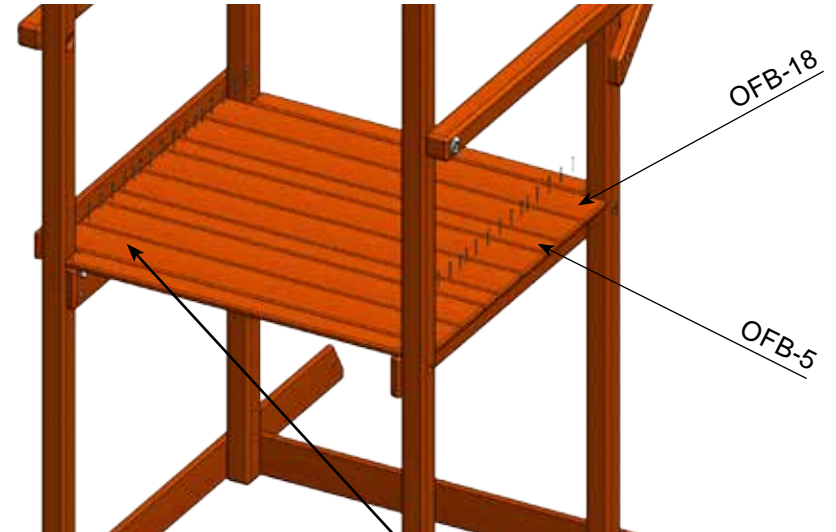
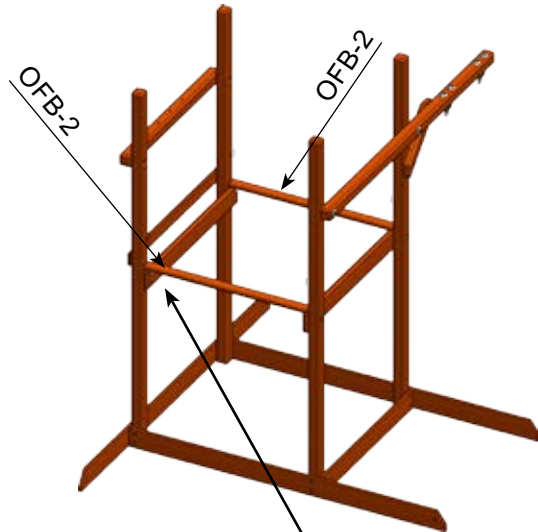

Main Assembly

PARTS NEEDED

- OFB-23- 47 3/8" Side Support- (2)
- OFB-24- 55 7/8" Rockwall Support- (2)

HARDWARE NEEDED

- OFH-18- 1/4" USS Flatwasher- (4)
- OFH-2- 1/4" Hex Lag Screw- (4)
- OFH-21- 3/8" 4-Prong T-Nut- (4)
- OFH-19- 3/8" USS Flatwasher- (4)
- OFH-15- 3/8" x 2" Hex Bolt- (4)

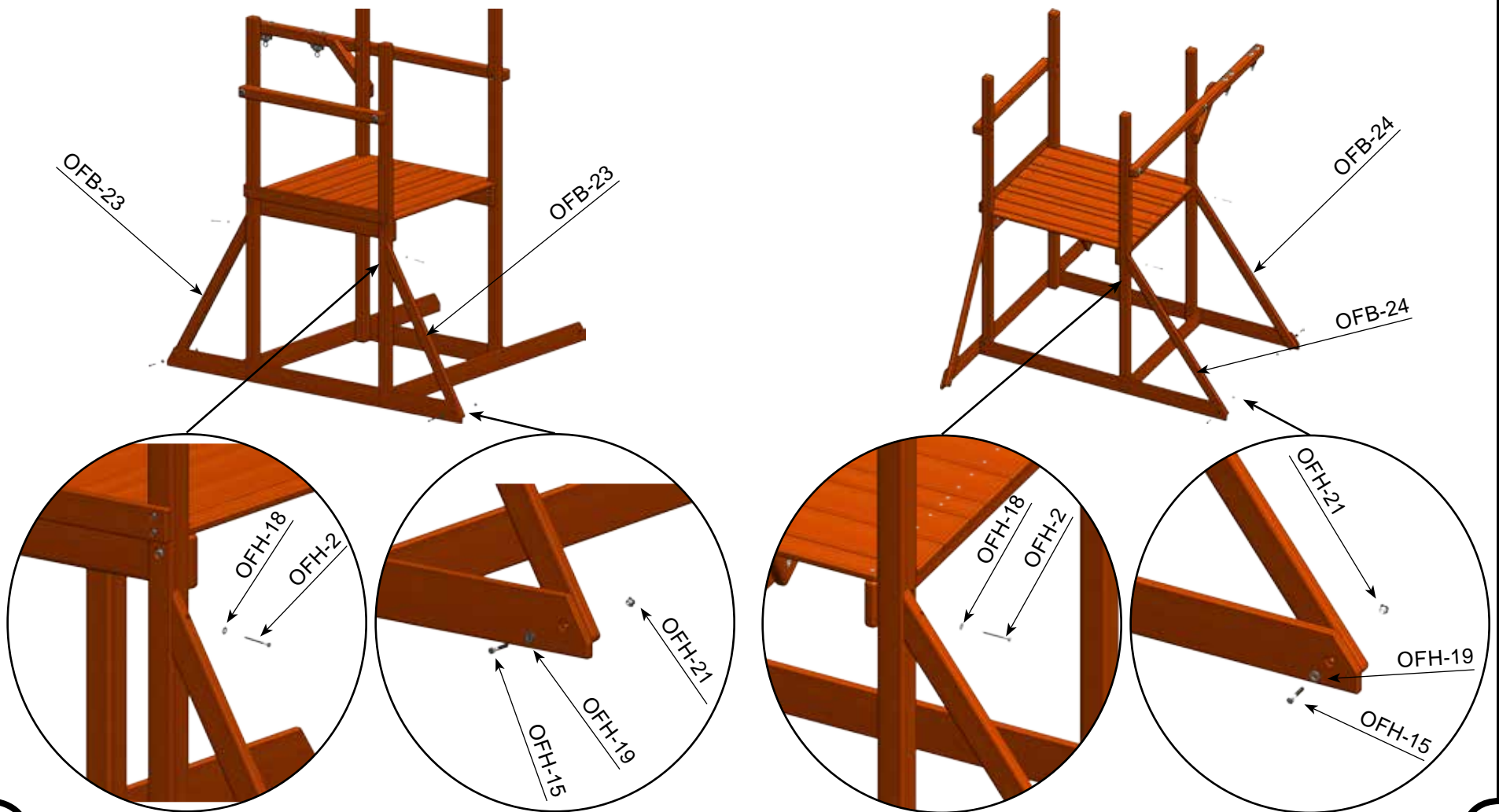

Rockwall Assembly

PARTS NEEDED

OFB-16- 44" Rockwall Board w/ Holes-	(5)
OFB-15- 44" Blank Rockwall Board-	(6)
OFB-17- 44" Rockwall Board w/ Rope Hole-	(1)
OFB-6- 44" Blank Rockwall Board- Ripped-	(1)

HARDWARE NEEDED

RWH-3- 1/4" x 1 1/4" Pan Phillips M/S-	(20)
RWH-4- 1/4" 4-Prong T-Nut-	(20)
RWH-5- 1/4" USS Flatwasher-	(20)
RWH-2- 2" Coated Deck Screw-	(44)

Repeat for all OFB-16's

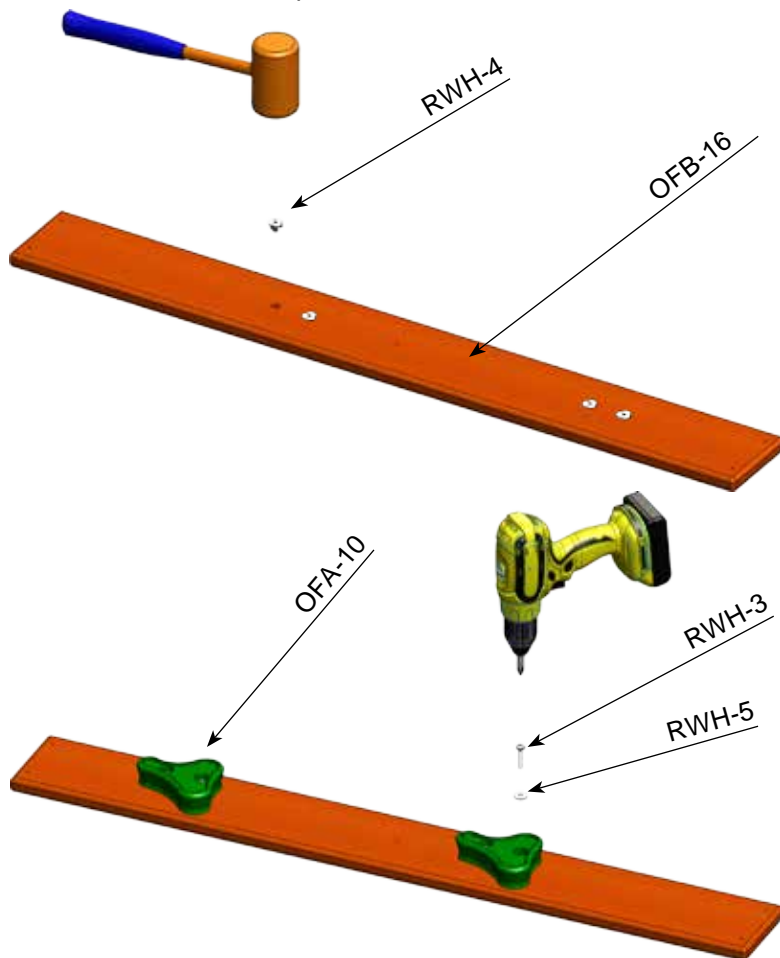

Start at the top and work down when putting on Rockwall Boards

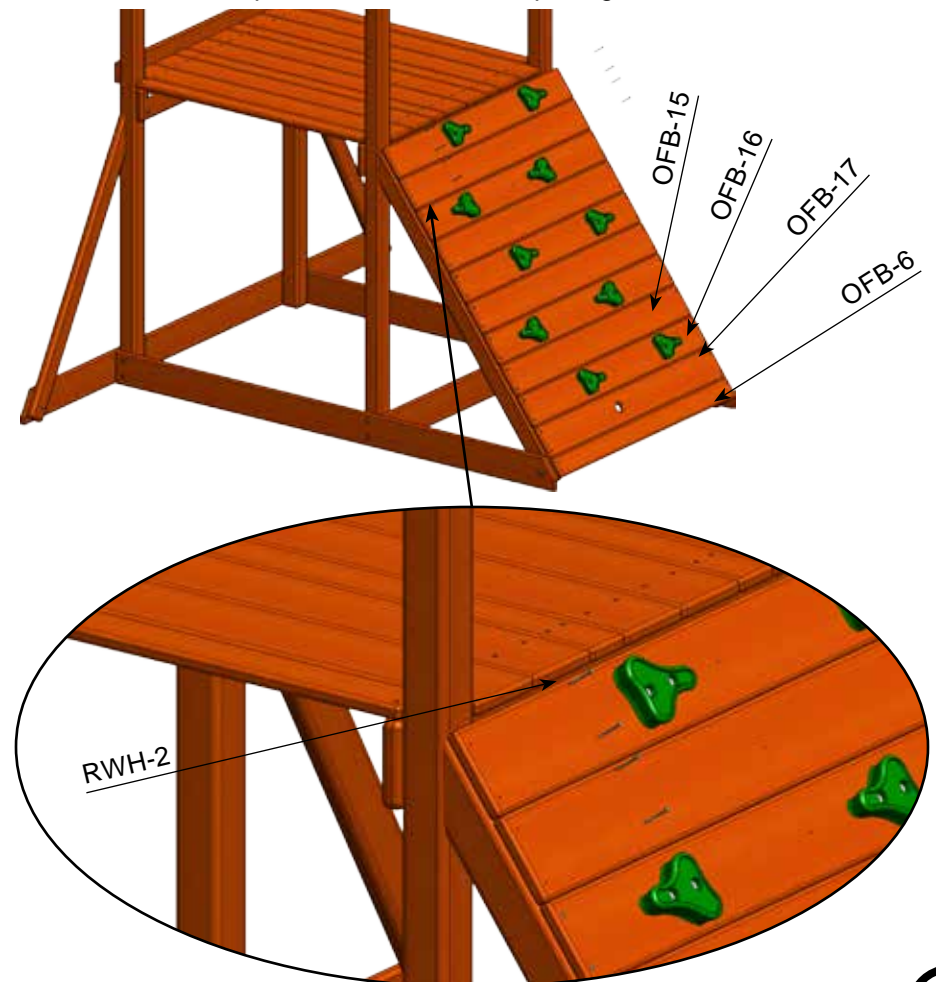

Main Assembly

PARTS NEEDED

OFB-7- 43 1/2" Deck Support- (1)
OFB-10- 48" Deck Side Facia- (1)

HARDWARE NEEDED

OFH-5- 1 1/2" Coated Deck Screw- (10)
OFH-2- 1/4" x 3" Hex Lag Screw- (4)
OFH-18- 1/4" USS Flatwasher- (4)

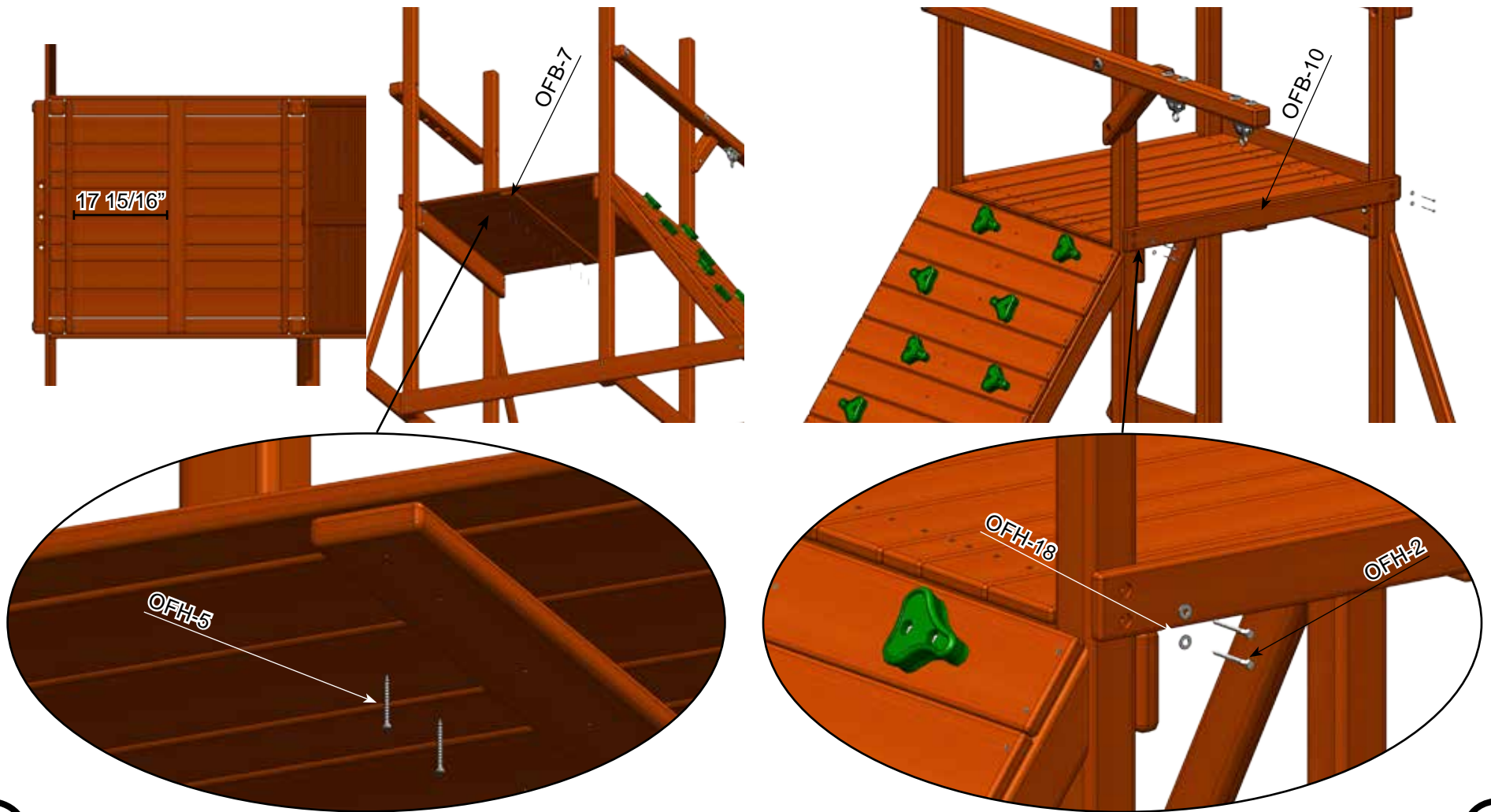

Main Assembly

PARTS NEEDED

- OFB-11- 48" Ladder Side Facia- (1)
- OFB-22- 17" Ladder Step- (4)
- OFA-8- 90 Degree Ladder Bracket- (2)

HARDWARE NEEDED

- OFH-18- 1/4" USS Flatwasher- (4)
- OFH-2- 1/4" x 3" Hex Lag Screw- (4)
- SLH-1- 3/8" x 1 1/2" Hex Bolt- (2)
- SLH-3- 3/8" Split Lockwasher- (2)
- SLH-2- 3/8" 4-Prong T-Nut- (2)

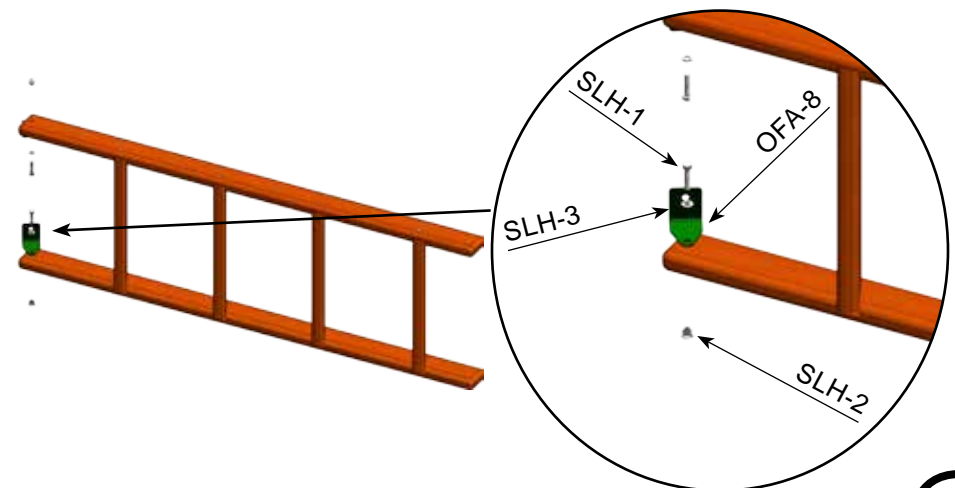
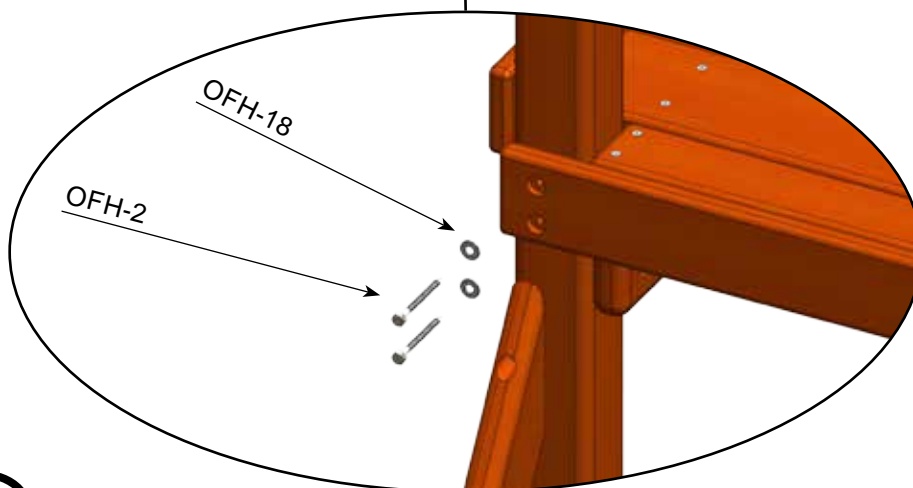
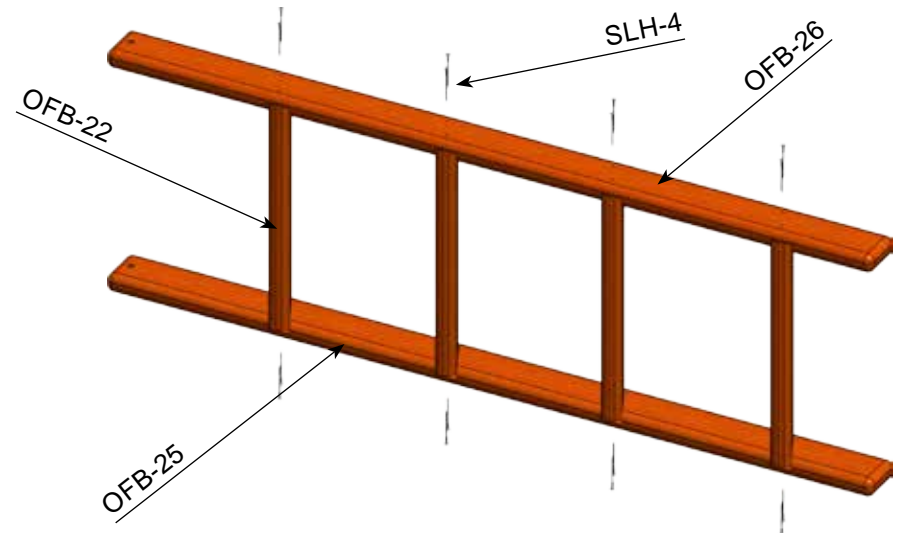
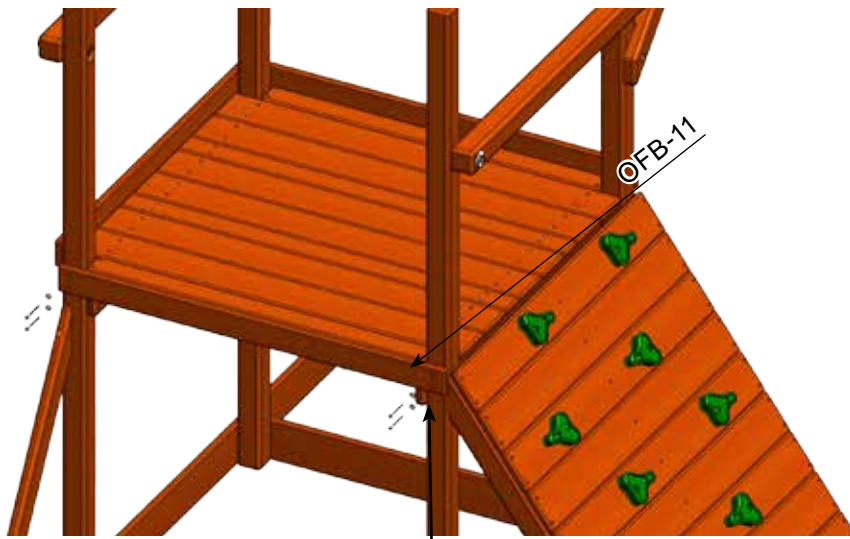

Main Assembly

PARTS NEEDED

Ladder Assembly- (1)
OFB-4- 48" Center Post Facia- (2)

HARDWARE NEEDED

OFH-17- 3/8" Split Lockwasher- (2)
OFH-16- 3/8" x 1" Hex Bolt- (2)
OFH-18- 1/4" USS Flatwasher- (4)
OFH-2- 1/4" x 3" Hex Lag Screw- (4)

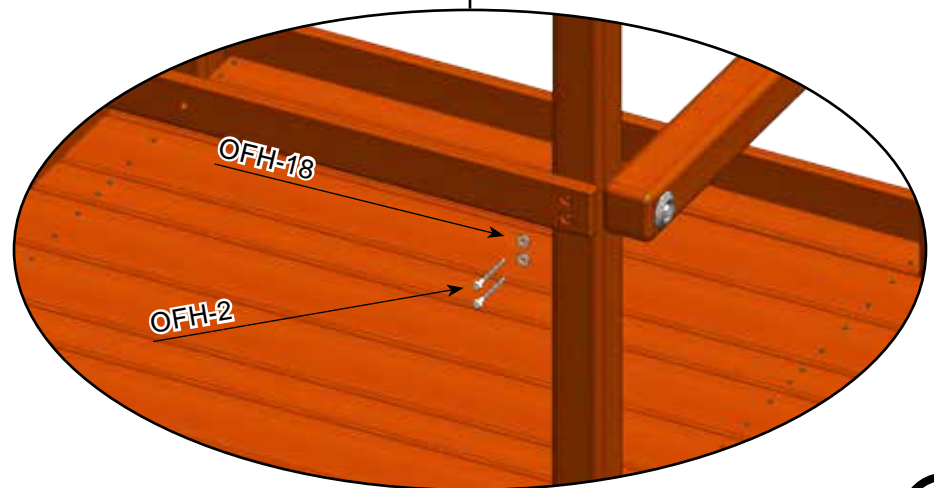
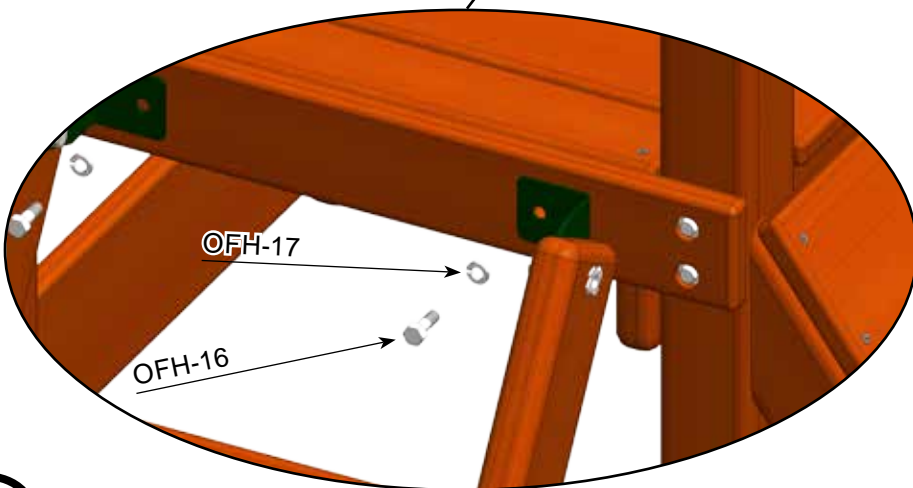
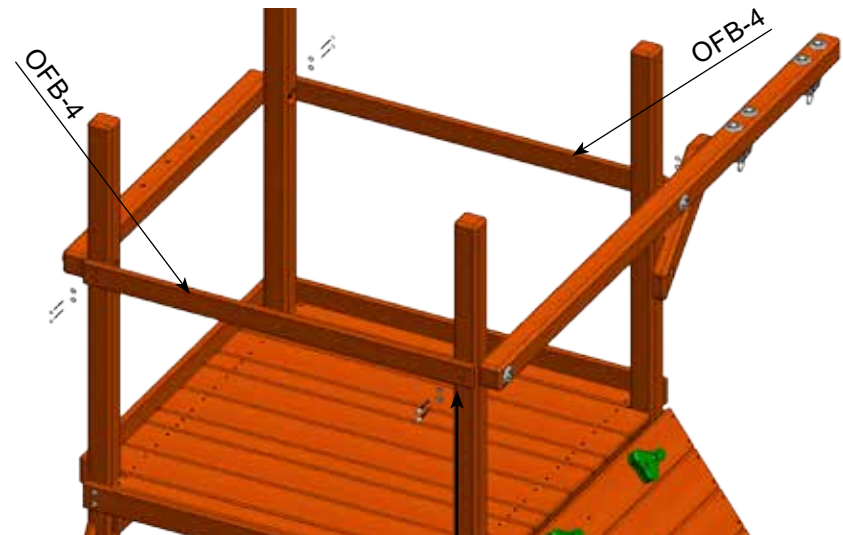
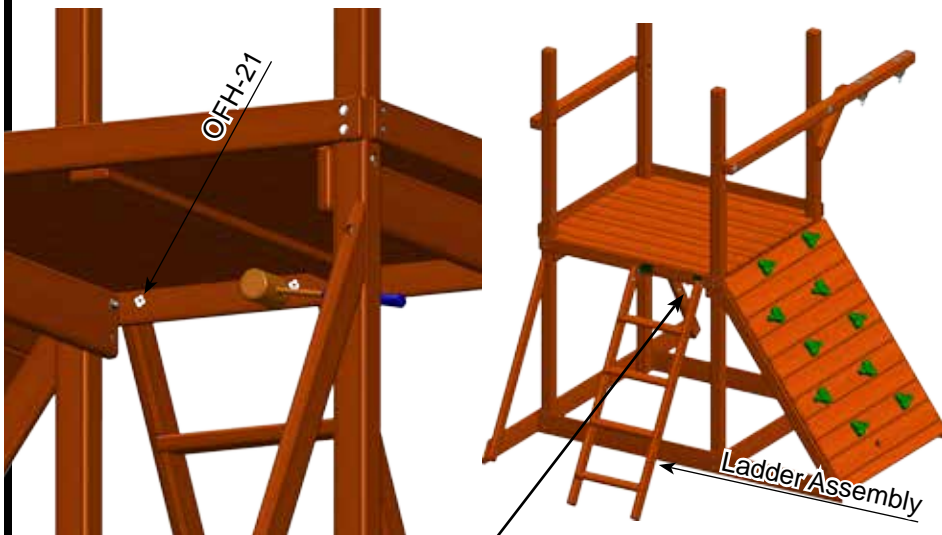

Main Assembly

PARTS NEEDED

- OFB-13- 68" Center Post- (2)
- OFA-2- 1 1/4" Playgrip Safety Handle- (2)
- OFA-7- Small 90 Degree Bracket- (2)

HARDWARE NEEDED

- | | |
|---|------------------------------------|
| OFH-9- 3/8" x 2 1/2" Carriage Bolt- (2) | OFH-20- 1/2" USS Flatwasher- (2) |
| OFH-19- 3/8" USS Flatwasher- (2) | OFH-17- 3/8" Split Lockwasher- (2) |
| OFH-8- 3/8" Hex Nut- (2) | OFH-1- 3/8" Acorn Nut Plated- (2) |
| OFH-4- #14 x 1" Pan Phillips T/S- (8) | OFH-18- 1/4" USS Flatwasher- (8) |

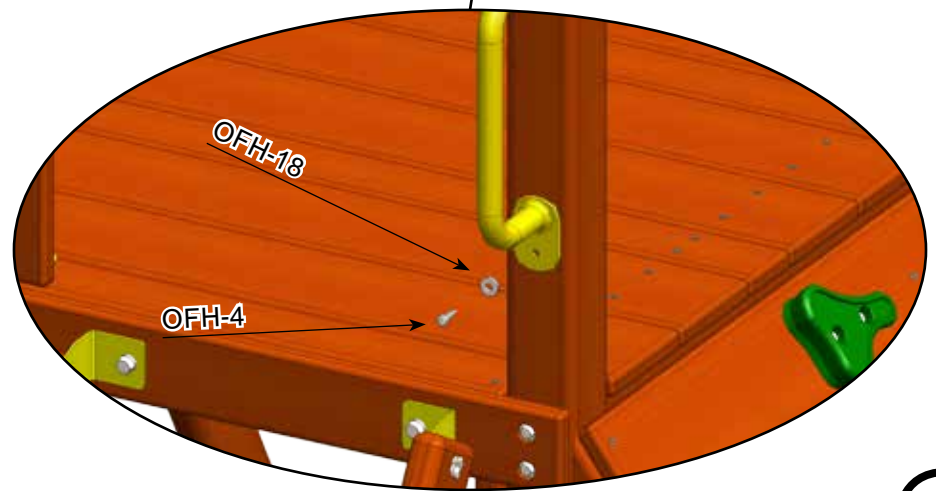
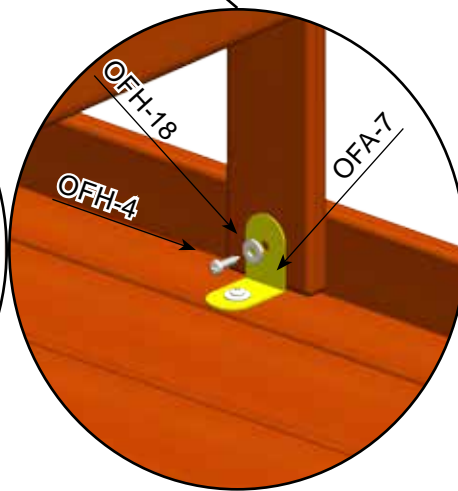
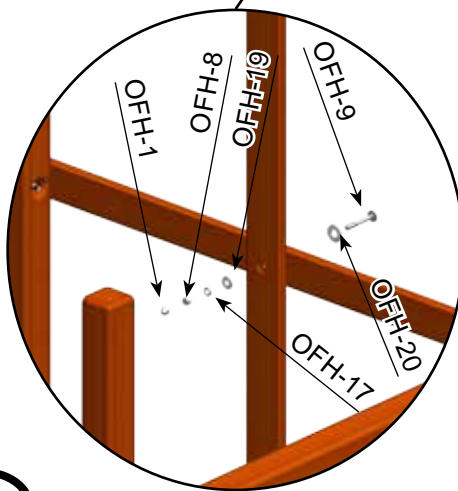
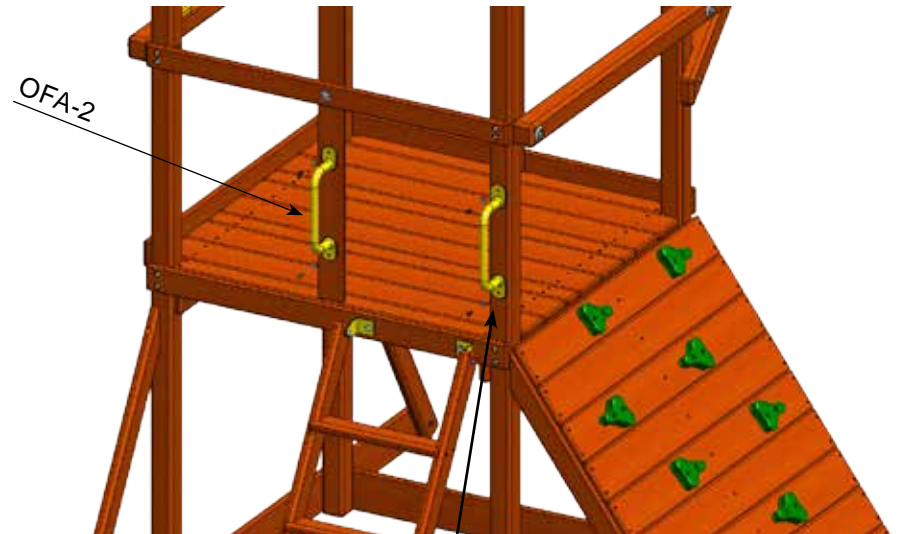
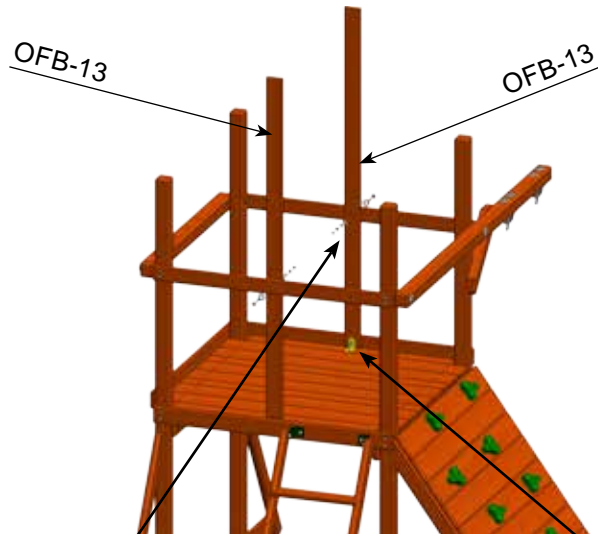

Main Assembly

PARTS NEEDED

OFB-1- 27 5/16" Rail Picket- (15)

HARDWARE NEEDED

OFH-5- 1 1/2" Coated Deck Screw- (30)

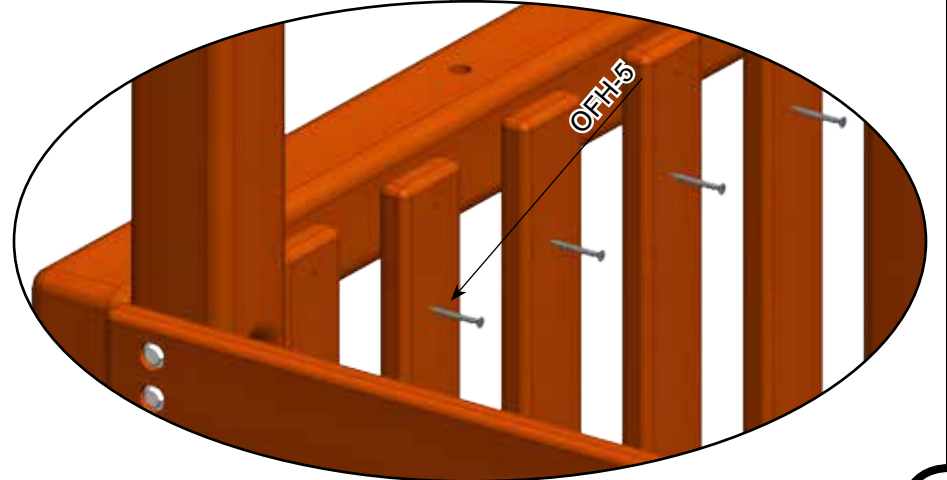
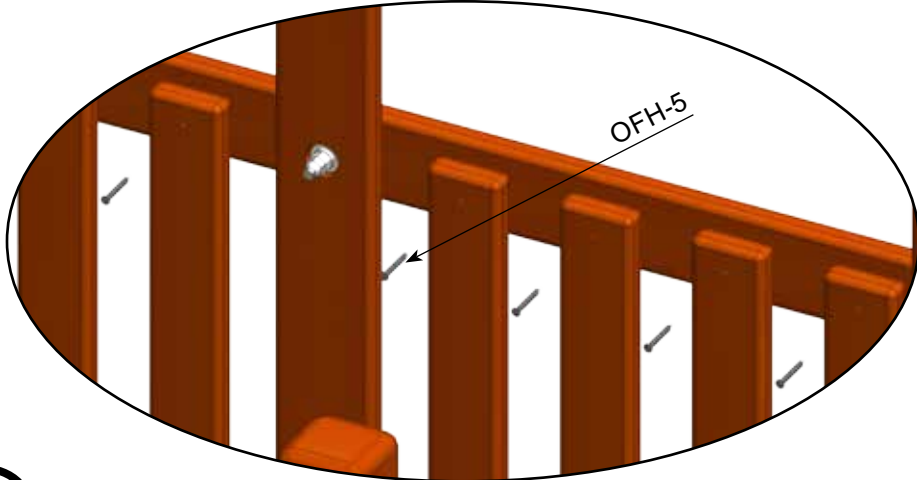
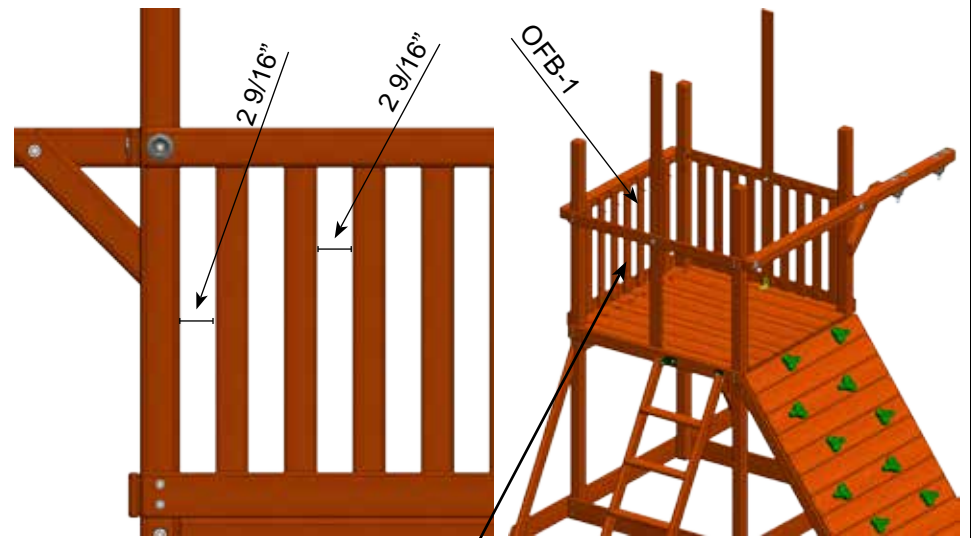
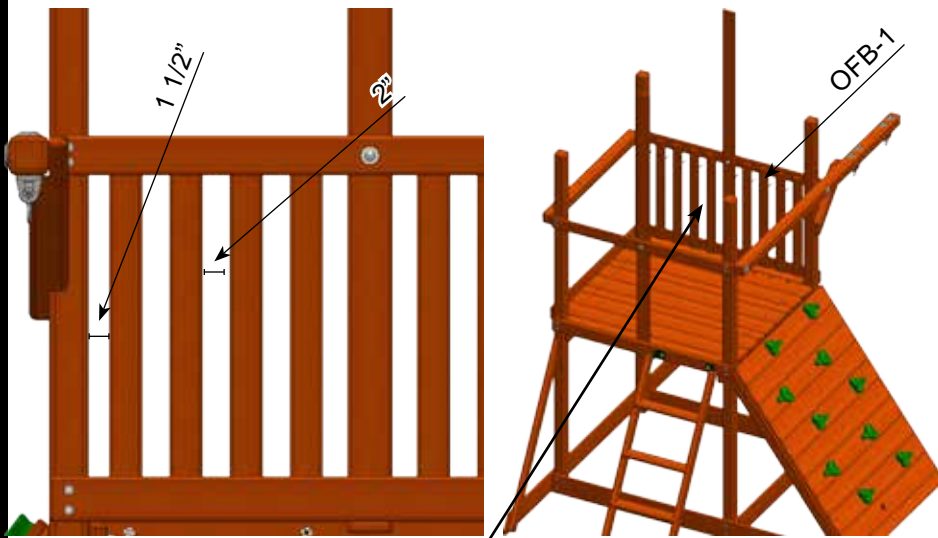

Main Assembly

PARTS NEEDED

OFB-12- 55 1/4" Rockwall Center Support- (1)
OFB-29- 11" Rope Block- (1)

HARDWARE NEEDED

RWH-1- 1 1/2" Coated Deck Screw- (11)
OFH-19- 3/8" USS Flatwasher- (2)
OFH-11- 3/8" x 5" Hex Lag Screw- (2)

Center the OFB-12 on backside of Rockwall

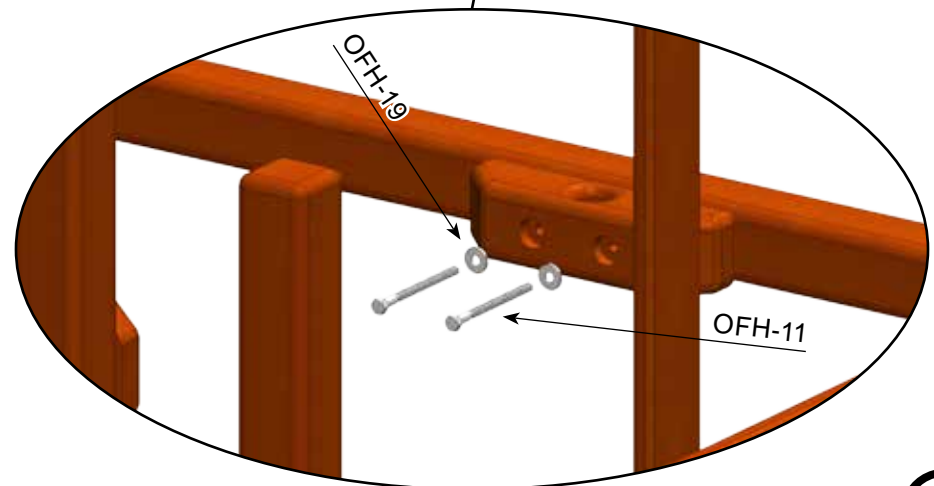
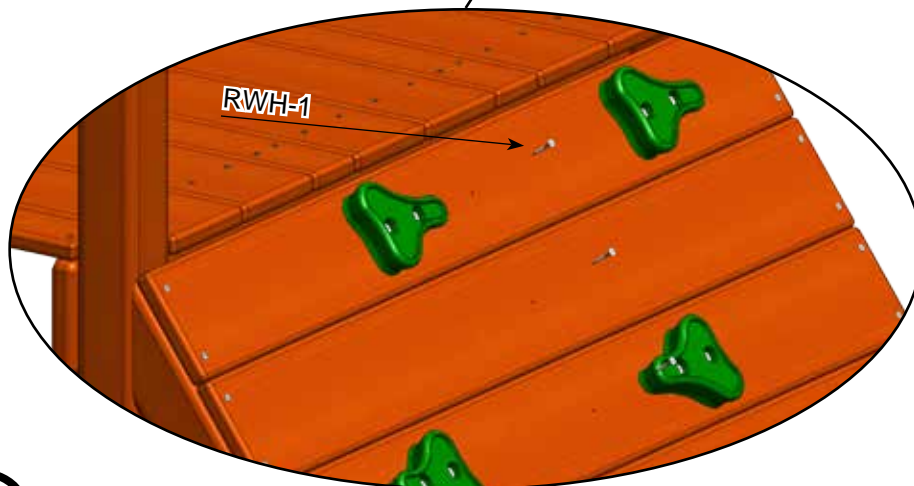
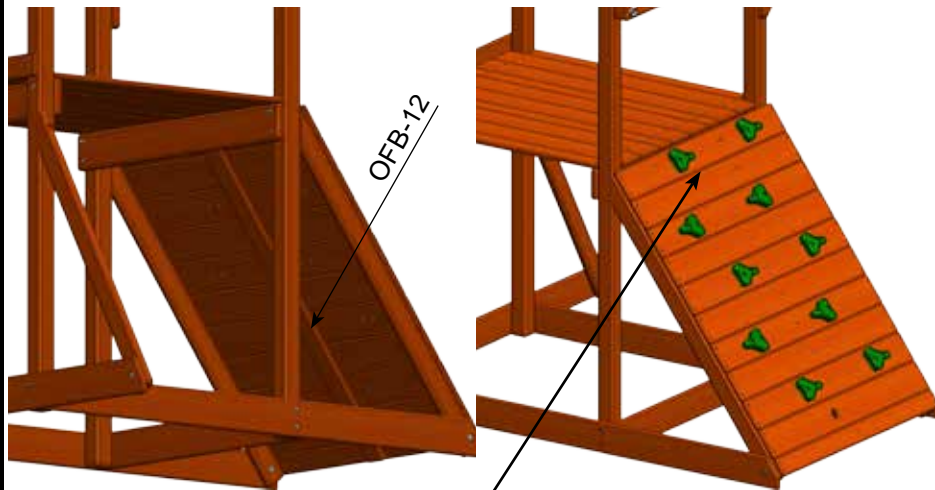

Main Assembly

PARTS NEEDED

- OFB-3- 44" End Tarp Board- (2)
- OFB-8- 44" Center Tarp Board- (1)
- OFA-14- 37" x 73" Fort Tarp- (1)

HARDWARE NEEDED

- OFH-6- 2" Coated Deck Screw- (12)
- OFA-14- 5/8" Phillips Screw Snaps w/ Tarp- (8)

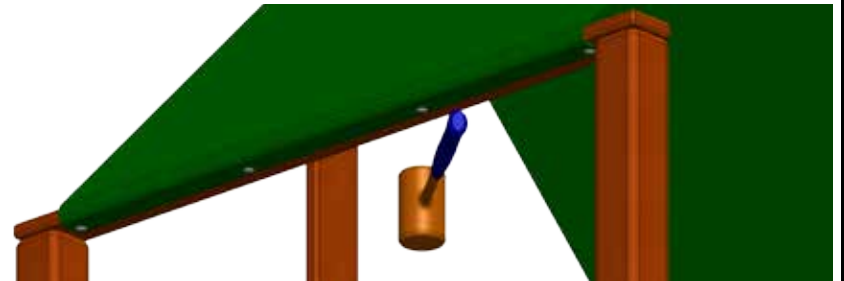
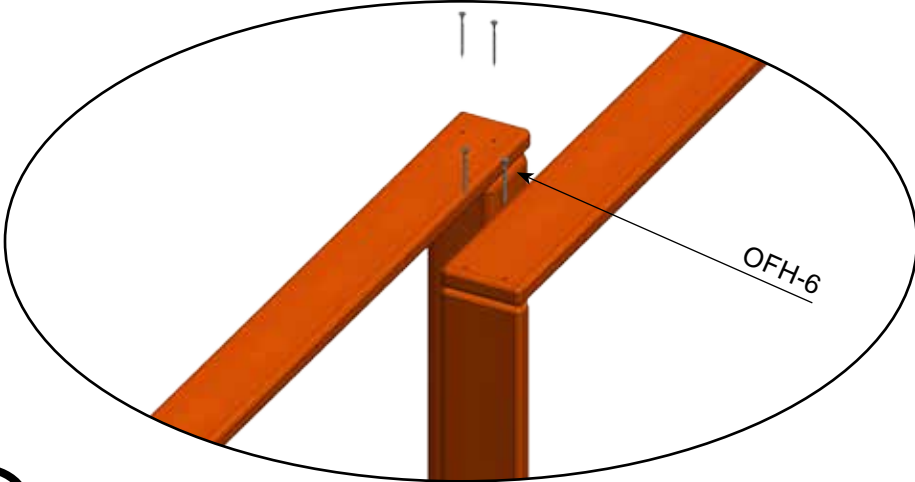
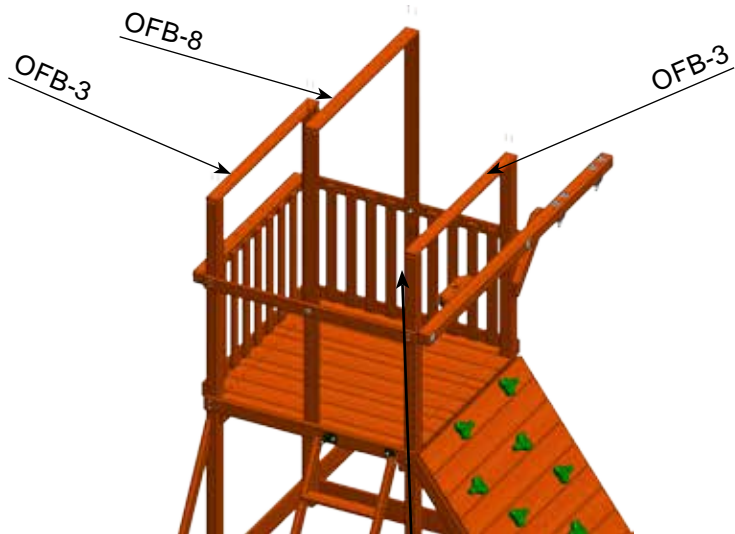

Wrap Tarp over the Tarp Board and mark button placements. Then screw the 5/8" Phillips Screw Snaps into the marked locations.



Then place the tarp on the snaps



Main Assembly

PARTS NEEDED

- OFA-5- 16" Trapeze Bar w/ Rings- (1)
- OFA-4- 10mm x 100mm Spring Clip- (2)
- OFA-9- 12' Rope- (1)

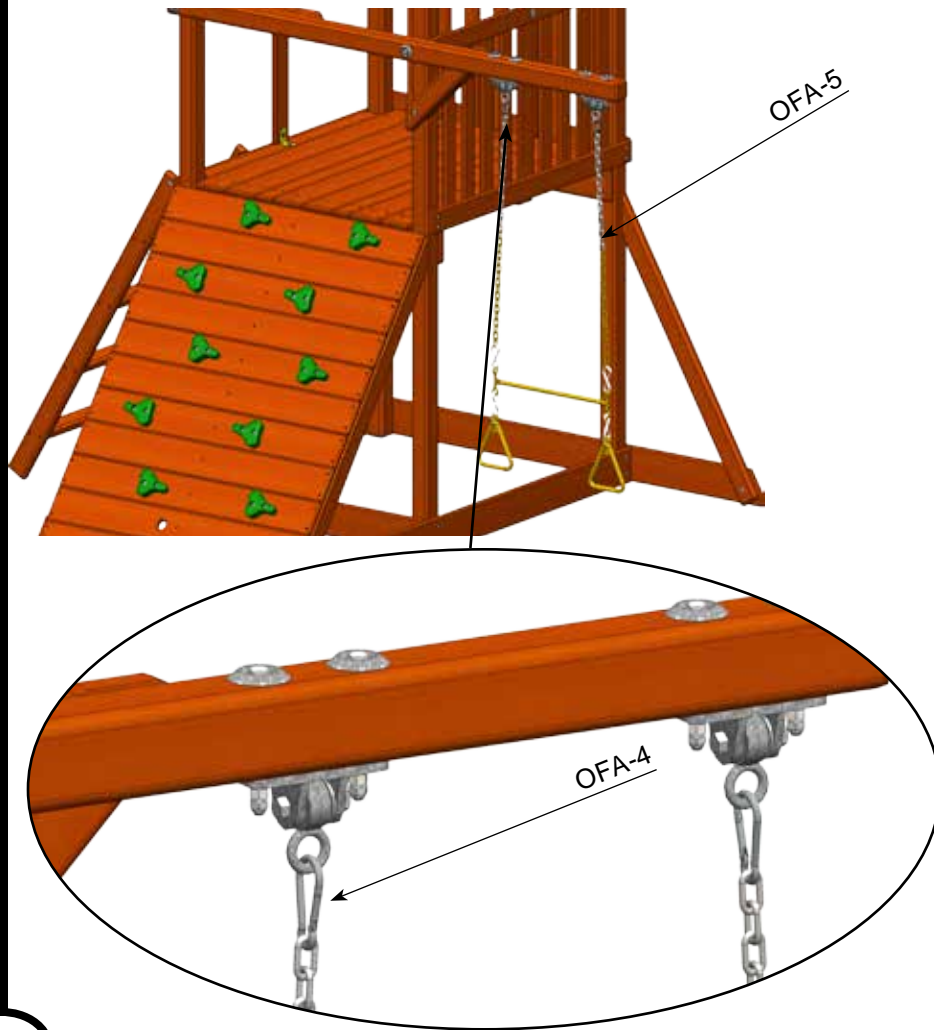

Slip rope through the rope block and tie a knot, then tie a couple more knots on the way down to the Rockwall Rope hole, slip through then tie a knot.



Swingbeam Assembly

PARTS NEEDED

OFB-31- 13" A-Frame Block-
 OFB-28- 7 13/16" Small A-Frame Block-
 OFB-30- 13" A-Frame Block Sunk-
 OFB-38- 91 3/4" 2 Pos. Swingbeam-
 OFA-1- Ductile Iron Swing Hanger-

(1) SBH-16- 3/8" x 9" Hex Bolt-
 (1) SBH-13- 3/8" USS Flatwasher-
 (1) SBH-6- 3/8" Hex Nut-
 (1) SBH-10- 3/8" Nylon Insert Locknut-
 (4) SBH-8- 3/8" x 6 1/2" Hex Bolt-

HARDWARE NEEDED

(2) SBH-19- 3/8" Bolt Cup- (10)
 (10) SBH-11- 3/8" Split Lockwasher- (10)
 (2) SBH-1- 3/8" Acorn Nut Plated- (10)
 (10) SBH-10- 3/8" Nylon Insert Locknut- (10)
 (8) SBH-8- 3/8" x 6 1/2" Hex Bolt-

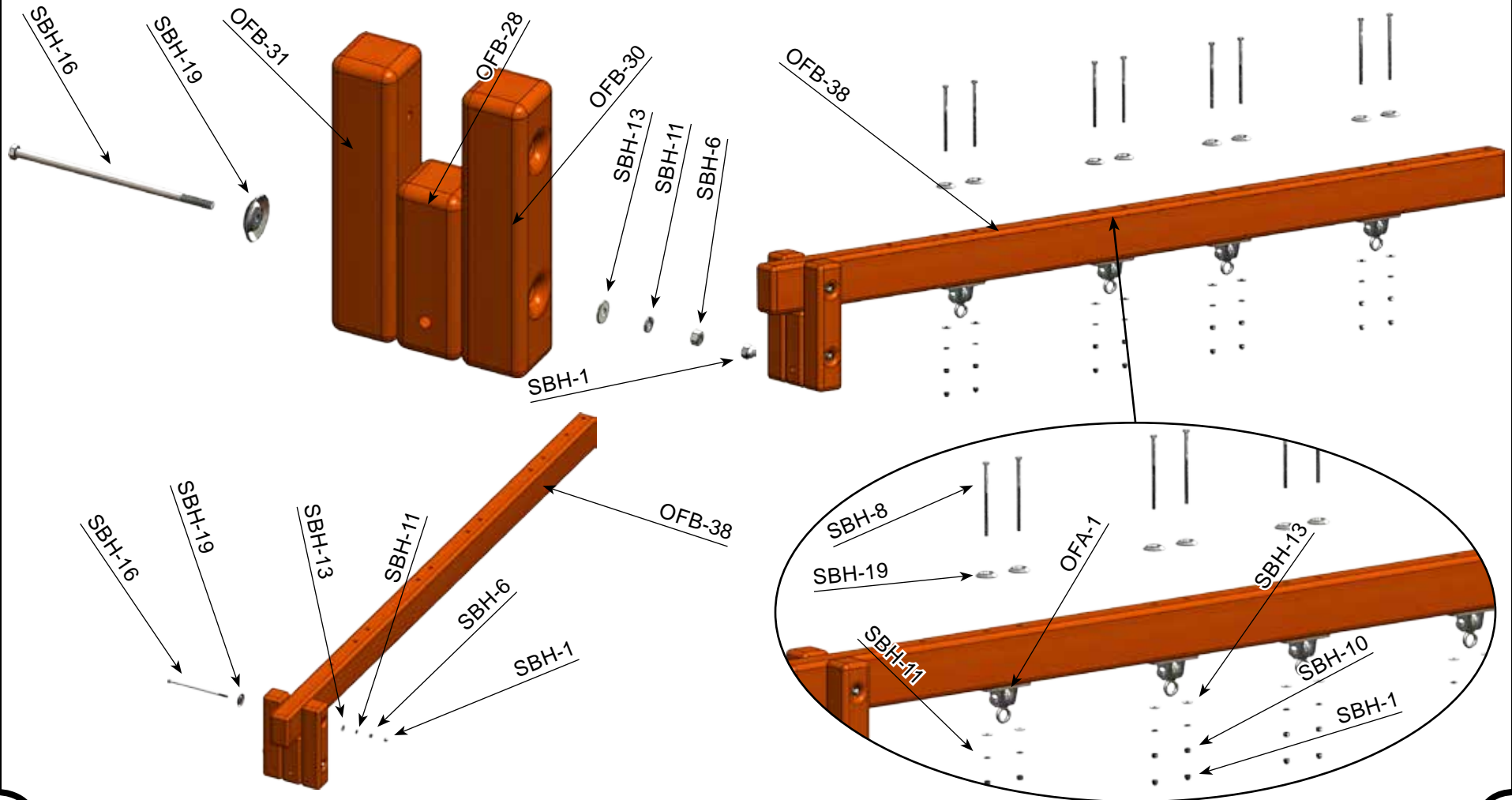

Swingbeam Assembly

PARTS NEEDED

- OFB-36- 92" A-Frame Leg- (2)
- OFA-3- Swinbeam 45 Degree Bracket- (1)
- OFA-6- Swingbeam Tri-Plate- (1)

- SBH-18- 1/2" x 10 1/2" Hex Bolt- (1)
- SBH-12- 3/8" Split Lockwasher- (4)
- SBH-2- 3/8" Acor Nut Plated- (4)
- SBH-15- 3/4" USS Flatwasher- (3)

HARDWARE NEEDED

- SBH-14- 1/2" USS Flatwasher- (5)
- SBH-7- 1/2" Hex Nut- (4)
- SBH-4- 1/2" x 6 1/2" Carriage Bolt- (1)
- SBH-3- 1/2" x 3" Carriage Bolt- (2)

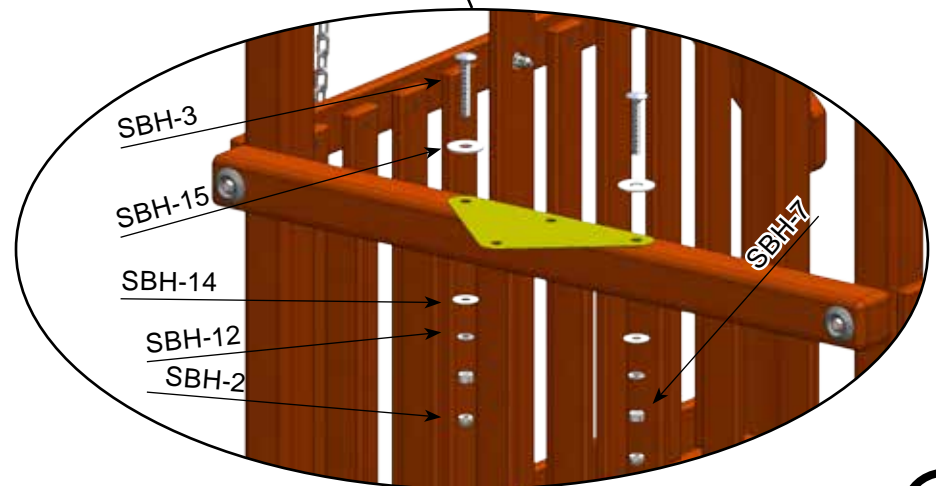
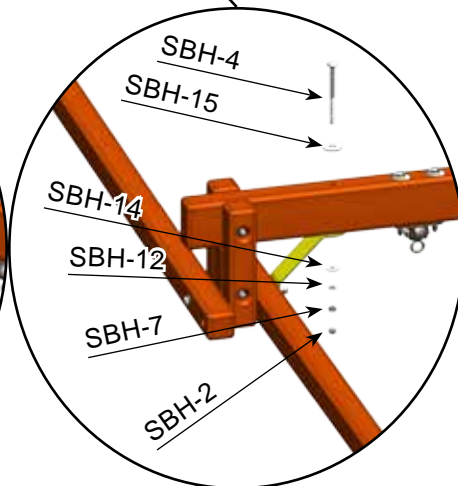
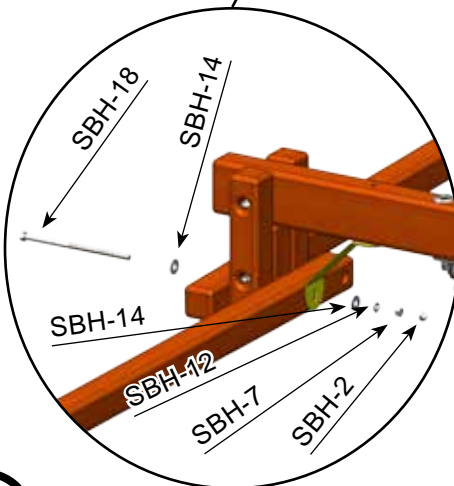
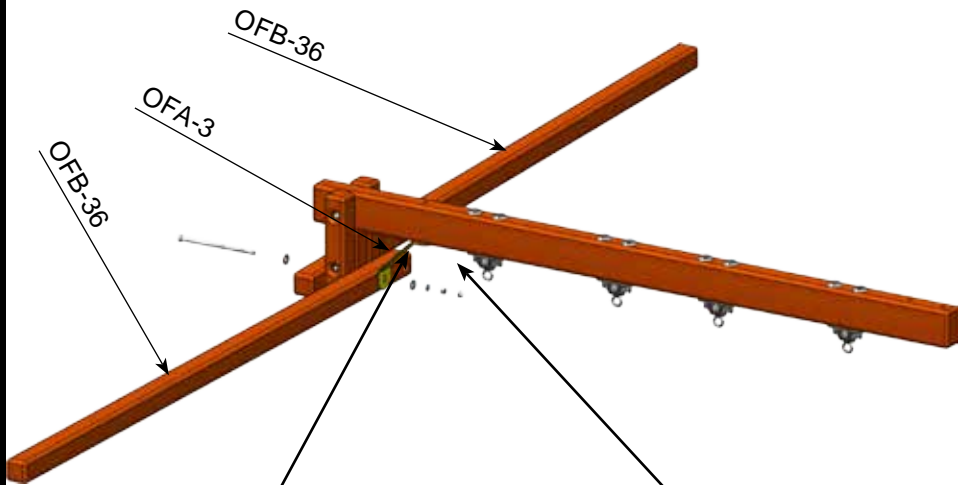

Swingbeam Install

PARTS NEEDED

OFB-34- 60" A-Frame Crossmember- (1)
Swingbeam Assembly- (1)

SBH-4- 1/2" x 6 1/2" Carriage Bolt- (3)
SBH-14- 1/2" USS Flatwasher- (4)
SBH-7- 1/2" Hex Nut- (4)
SBH-5- 1/2" x 8 1/2" Carriage Bolt- (1)

HARDWARE NEEDED

SBH-15- 3/4" USS Flatwasher- (4)
SBH-12- 1/2" Split Lockwasher- (4)
SBH-2- 1/2" Acron Nut Plated- (4)

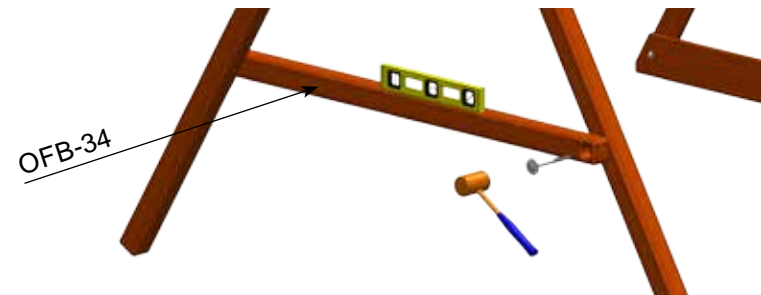
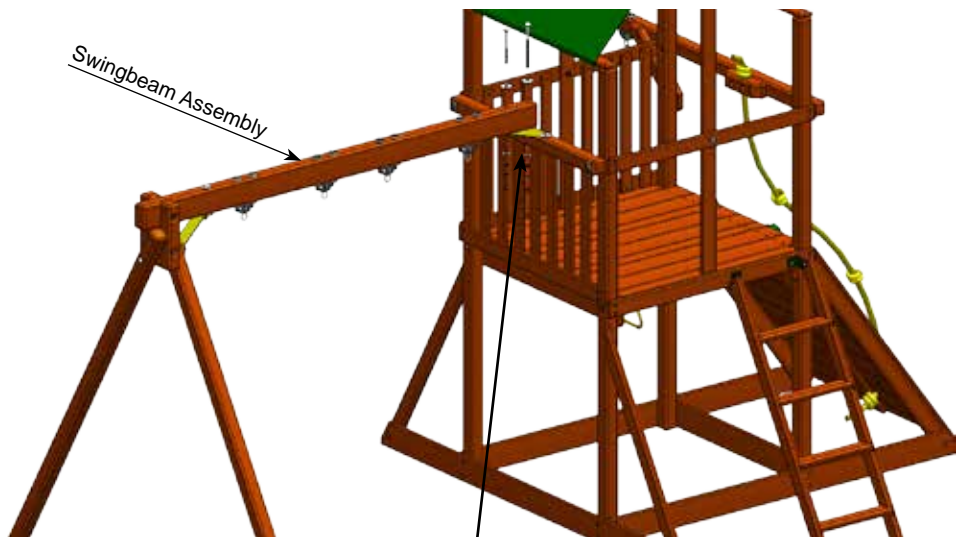

Once the Swingbeam is level, take OFB-34 and level it out between the legs and mark the holes for drilling.

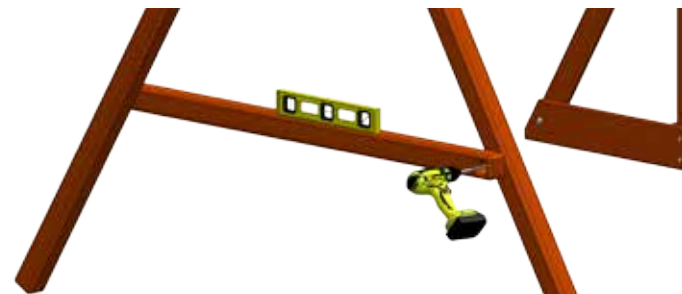

With the holes marked use a 9/16" drill bit and make a through hole and bolt down as shown below.

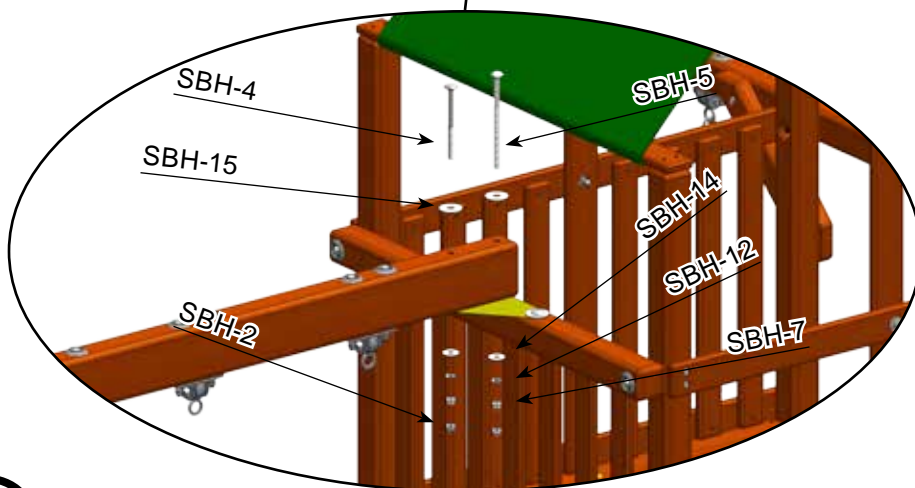
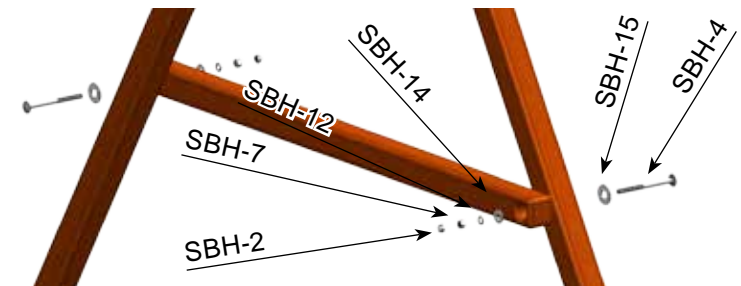

Main Assembly

PARTS NEEDED

OFA-4-Spring Clips 10mm x 100mm- (4)
OFA-11- 56" Chained Belt Swing- (2)

HARDWARE NEEDED

SBH-13- 3/8" USS Flatwasher- (2)
SBH-9- 3/8" x 5" Hex Lag Screw- (2)

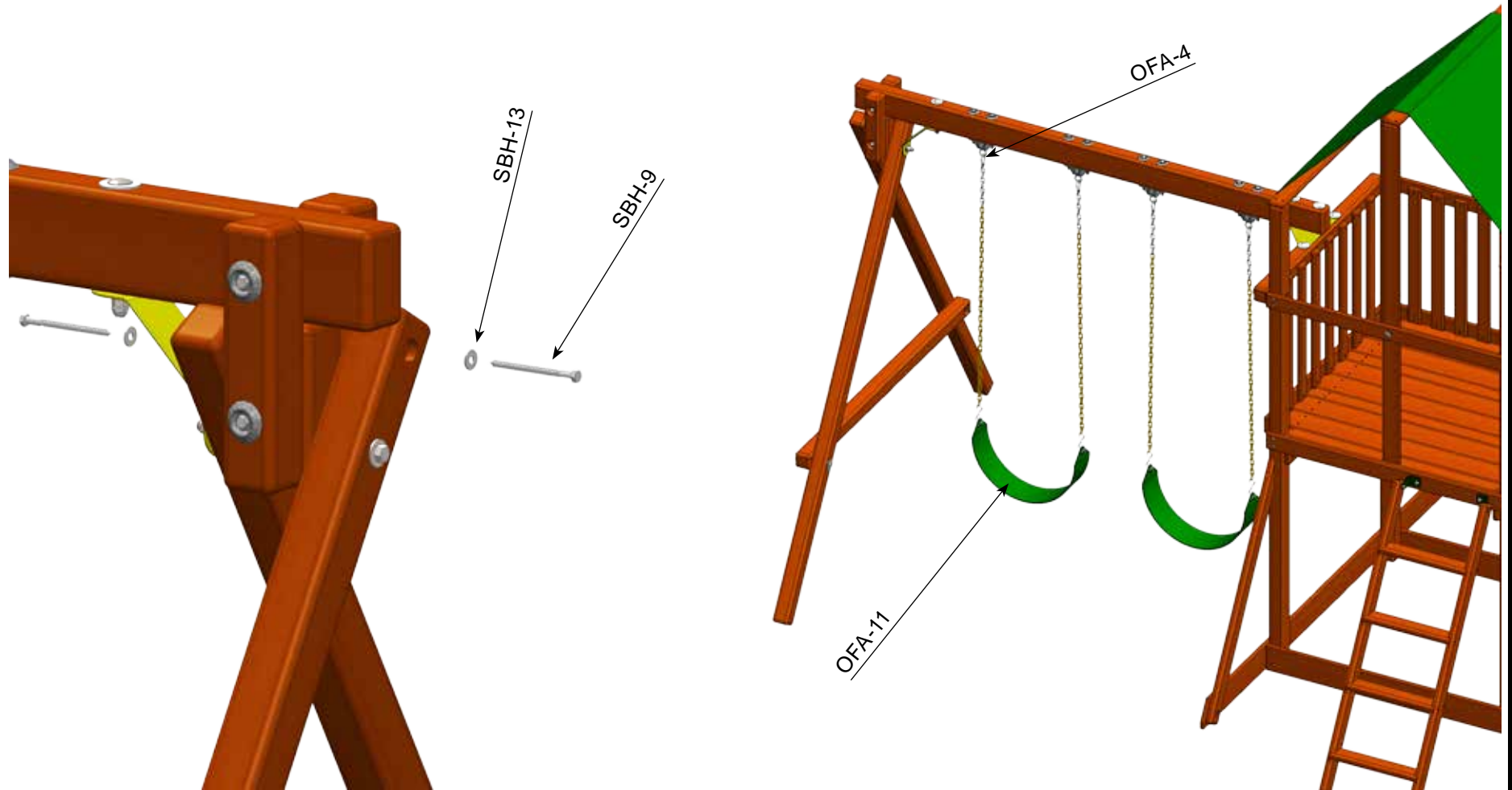

Accessory Install

PARTS NEEDED

OFA-13- 12" Ship's Wheel- (1)
OFA-12- Telescope- (1)

HARDWARE NEEDED

Hardware with Accessories



